

A new ‘edge-mounted’ actuator: a new compact design

Angus Condie; Xaar plc; Cambridge, UK; James Arnold; Xaar plc; Cambridge, UK; Phil Mead; Xaar plc; Huntingdon, UK; Ian Starling; Xaar plc; Cambridge, UK.

Abstract

Xaar has deployed its Hybrid Side Shooter™ actuator technology successfully in its Xaar 1001/2 printhead. The ejection of ink from the ‘side’ of the ink channel and not the conventional ‘end’ of the ink channel has enabled it to use its patented Through-Flow technology (TF Technology™): This has transformed printing reliability and has led to the adoption of digital ink jet into single pass industrial printing; most noticeably for printing decoration of ceramic tiles. Xaar has now developed a new edge-mounted actuator architecture, which builds on the advantages of the side-shooter actuator and enables the capability to produce compact multiple row printheads and also improves manufacturing efficiency by using a ‘wafer-scale’ approach. This paper details some of the advantages of this new edge-mounted actuator architecture.

Background: Hybrid side-shooter actuator architecture and through-flow technology

Xaar’s hybrid side-shooter actuator design launched with the Xaar 1001 in 2007 combined several advantageous features for both low fabrication costs and operational advantages when compared to previous ‘end-shooter’ actuator designs:-

- (a) The efficient use of PZT material with the PZT confined to the active channeled component only and other cheaper fabricated materials used for the remainder of the actuator.
- (b) The nozzle plate additionally acting as the mechanical restraint for the actuated channel walls - removing the need for an additional channel-cover component used on end-shooter designs.
- (c) The ‘double-ended’ ink channel enabling two acoustic waves to be generated resulting in a reduced drive voltage compared to the single ended end shooter actuator.
- (d) The nozzle firing from the ‘side’ of the channel enabling ink to flow past the rear of the nozzle to sweep away ingested air during operation, enabling ink channels to self-recover and significantly improving printing reliability with the use of through-flow technology .
- (e) The combination of through-flow and a ‘double-ended’ ink channel enabling higher actuator ink pumping power without starvation.

The ‘edge-mounted’ has been developed at Xaar to build on these core actuator design benefits and supplement them with improved manufacturing efficiency and improvements in print performance. These benefits are discussed below.

Comparison of side-shooter and edge-mounted actuator architectures

A comparison of the side-shooter and new edge-mounted architecture is shown below in figure 1. The edge-mounted

architecture has the channeled PZT component now mounted on the edge of the substrate.

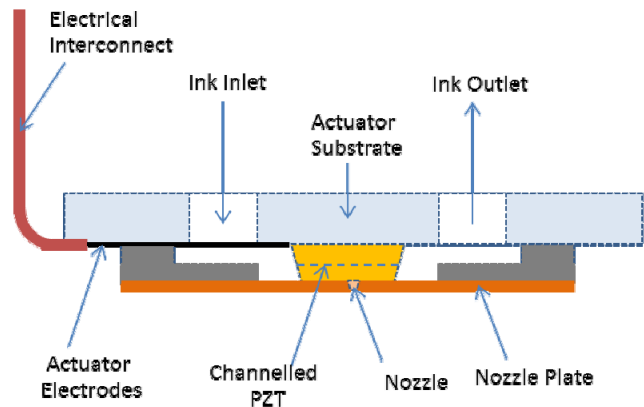

(a) ‘Side-Shooter’ Actuator

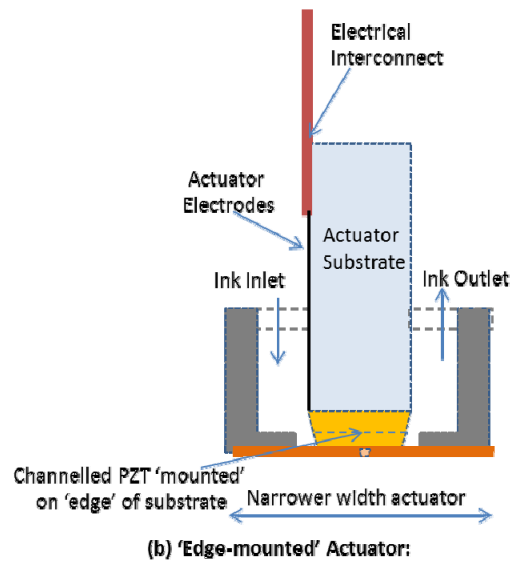

Figure 1 Comparison of side-shooter and edge-mounted architecture

The edge-mounted actuator design enables the electrodes to be positioned down the side of the actuator whilst maintaining the through-flow capability. The new architecture not only enables improvements to the performance of the side-shooter architecture but also improves manufacturing efficiency and its ability to be used in a number of applications. These advantages are detailed below:-

(i) Reduced width actuator

The immediate benefit of the edge-mounted actuator architecture is with the displacement of the electrodes: this results in a reduced width of the core actuator. This enables actuator modules to be closer packed for instance in multiple colour applications, which makes it easier to align the modules to one another.

(ii) Improved actuator rigidity

PZT is susceptible to changes in properties when subjected to stress. These stress induced changes in properties can result in variations in print performance of the final printhead.

The thin substrate for the side-shooter actuator makes it susceptible to stress during assembly into a printhead, e.g. stress imparted when ink manifold is attached to the actuator - the thermal induced stress is generated during cooling from the elevated curing temperature of the adhesive and the differential of the thermal coefficients of expansion of the two materials. The increase in thickness of the substrate for the edge-mounted actuator reduces the stress applied to the actuator during manufacturing and results in a reduced impact on print uniformity. Additionally, the reduced stress also results in a reduced distortion of the actuator and improved dimensional control of the nozzle plate; this results in improved drop placement accuracy with improved consistency of distance of the nozzle plate to the print media.

Two edge-mounted actuators are shown in figure 2: showing the channeled and metalized PZT mounted on the thick substrate. The electroded and reverse sides of actuator (showing actuator identification number) are also shown in figure 2.



Figure 2 Singulated edge-mounted actuators

(iii) Improved manufacturing efficiency

The reduced width of the edge shooter actuator makes this design more compatible with wafer scale manufacturing: where multiple actuators are produced from one PZT wafer/substrate assembly: The PZT wafer/substrate assembly is diced into separate actuator components after wafer machining and metalisation processes are completed. This not only overcomes the difficulty of processing single edge-mounted actuators with a high height to width aspect ratio it also improves PZT utilization - (more than

doubles PZT utilization – comparing the ‘edge-mounted’ and side-shooter actuators). The completion of PZT to substrate lamination, PZT machining, channel sawing and metalisation for multiple actuators as one process also improves manufacturing efficiency and the throughput through each process. A comparison of the process flow for the side shooter actuator process flow – where actuators are processed as single units after wafer diced into actuator tiles - and the wafer scale manufacture of the edge-mounted actuator is shown in figure 3. A picture of a completed wafers scale assembly after machining, sawing and metalisation is shown in figure 4.

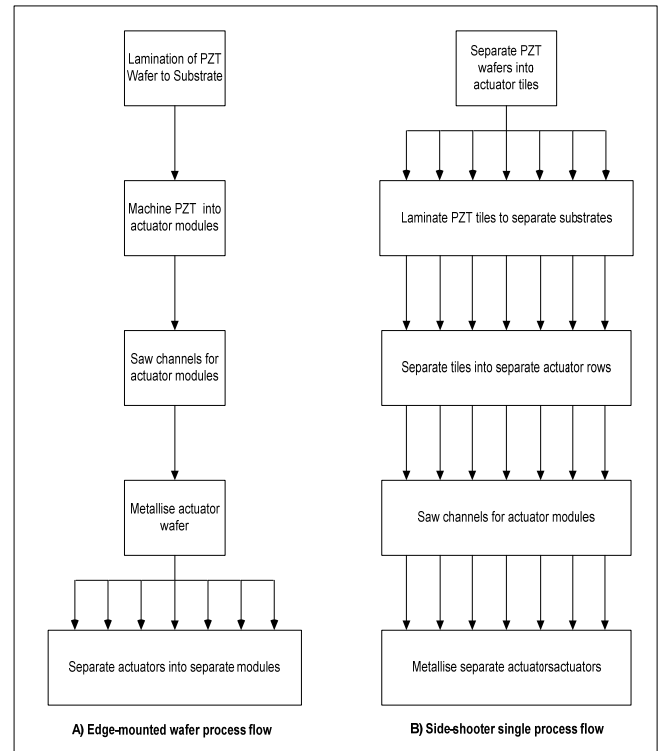

Figure 3 Comparison of edge-mounted and side-shooter actuator manufacturing process flows



Figure 4 Edge shooter wafer assembly prior to separation

(iv) Manufacturing flexibility and improved registration between rows

The wafer-scale manufacturing approach also presents the flexibility to separate the wafers in different configurations: e.g. into single row actuator or double row actuator etc. Furthermore, the machining can be completed such that the rows are intrinsically interleaved. This approach has been adopted for the Xaar 1001/2 with the interleaving of two 180dpi actuators to achieve a 360 dpi printhead, however, the wafer scale assembly of multiple actuator rows means that this approach can be extended to interleaving 3 and 4 row actuators for the edge shooter design.

Additionally the completion of the channel sawing of all actuators within a wafer at the same time ensures that all actuators are geometrically well matched and that process variations are minimized.

(v) Removal of periodic holes in actuator substrate

The edge-mounted architecture overcomes the necessity for multiple ink inlets and ink outlets as part of the actuator substrate. The ink inlets and outlets are implemented in a periodic array for the side-shooter actuator Xaar 1002 printhead: This periodic array of ink ports imparts periodic variations on the actuator in terms of ink flow to each channel and stress imparted on the PZT of the actuator during manufacturing: these periodic variations result in periodic variation in print performance - the periodic nature of the variations increasing the sensitization of these print artifacts – hence small variations result in noticeable variation in print density.

The finite element analysis calculated periodic variations in stress on the PZT imparted by manifold attach is shown in figure 5 for both side-shooter and edge shooter actuators. The analysis has been calculated for different thicknesses of side-shooter actuator substrate and demonstrates the benefit of increasing the thickness of substrate to reduce the level of imparted stress on the PZT, however, the analysis of different thickness substrates for side shooter actuators also demonstrates that increasing substrate thickness also increases the periodic variation in stress for the side shooter actuator.

Measures have been taken to minimize the periodic variations for the Xaar 1002 side-shooter printhead by changing the relative positions of the inlet and outlet ports, but the variations cannot be wholly eliminated. The absence of inlet and outlet holes for the edge-mounted actuator means that as well as low level of stress there are no periodic variations in either stress or flow to affect variations in print performance – demonstrated in figure 5.

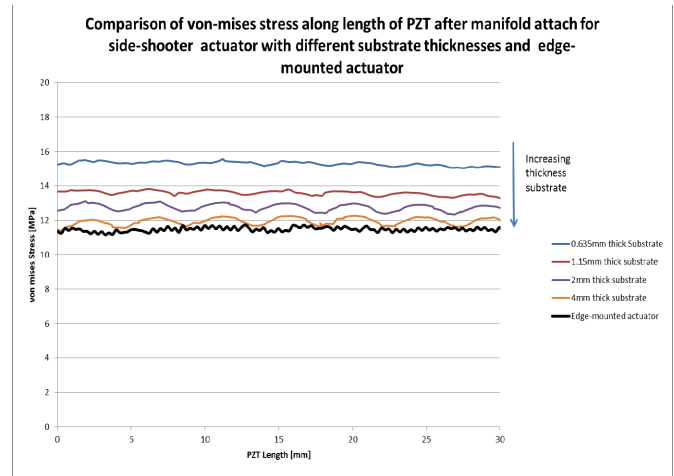

Figure 5 Comparison of stress distribution within PZT after manifold attach for central section of side-shooter and edge-mounted actuators

Xaar's exploitation of edge-mounted actuator

Xaar has initially deployed the edge-mounted actuator in the new Xaar 501 printhead (figure 6). This new narrow, single row 500 nozzle printhead (side elevation shown in figure 7) enables different colored printheads to be tightly packed with capability to operate in both non-throughflow and throughflow. The narrow printhead makes it particularly suitable for wide format graphics scanning applications.



Figure 6 Xaar 501 printhead incorporating an edge-mounted actuator



Figure 7 Side elevation of Xaar 501 printhead

A typical drop velocity and drop size characteristic of a 501 printhead is shown below figure 8 showing a flat response across the width of the actuator with no significant periodic variations in performance:

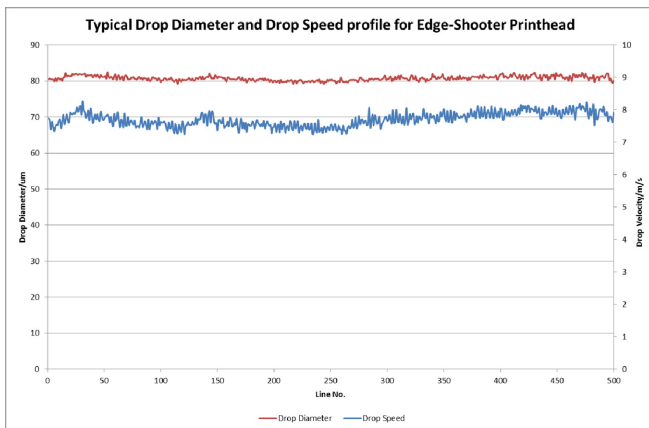

Figure 8 Side elevation of Xaar 501 printhead

Multiple row actuator printheads with edge-mounted actuator

Xaar is currently developing multi-row actuators combined in one printhead body utilizing the edge-mounted design: The

actuators modules are fabricated using wafer assembly detailed above enabling intrinsically aligned multiple actuators to be fabricated together for one printhead with closely matched performance.

A 4-row edge-mounted printhead concept is shown in figure 9; this will enable 720dpi printing: The close proximity of the actuator rows enables the printhead width to be minimized and hence printheads used in high resolution multiple colour applications to be closely packed.

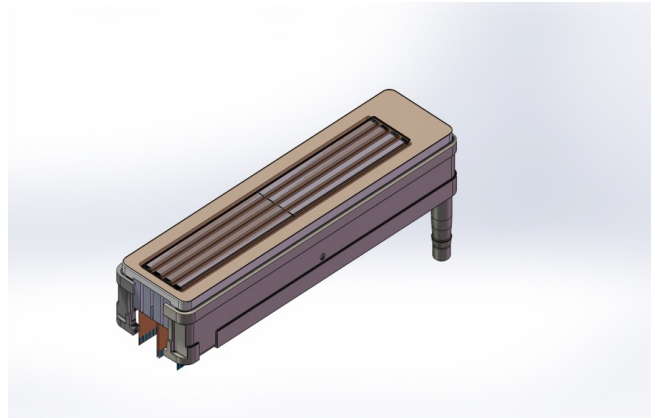

Figure 9 720 dpi printhead concept incorporating 4 edge-mounted actuators

Conclusions

Xaar has successfully developed a new edge-mounted actuator which has built on the features and performance of the Xaar's side-shooter actuator: The incorporation of the edge-mounted actuator into the new Xaar 501 has demonstrated some of its benefits in terms of manufacturing efficiency and printhead performance.

Author Biography

Angus Condie, a qualified Material scientist, has over 17 years' experience at Xaar and has been at the forefront of Xaar's actuator and printhead development: This has included the development of Xaar's revolutionary hybrid side-shooter actuator combined with through-flow (TF™) technology has enabled Xaar to lead the way in adoption of digital ink jet in many industrial applications. He has held roles of Process Development Manager, Actuator Manufacturing Manager and more latterly as Actuator Development Manager

He now holds the role Head of Technology for Xaar's bulk piezoelectric printhead products.