

Verification of Long-Range MTF Testing Through Intermediary Optics

Alexander Schwartz; Imatest, LLC; Boulder, CO
 Sarthak Tandon; Imatest, LLC; Boulder, CO
 Jackson Knappen; Imatest, LLC; Boulder, CO

Abstract

Measuring the MTF of an imaging system at its operational working distance is useful for understanding the system's use case performance. However, it is often not practical to test imaging systems at long distances (several meters to infinity), particularly in a production environment. Intermediate optics (relay lenses) can be used to simulate longer test distances. The Imatest Collimator Fixture is a machine developed for testing imaging systems at specified simulated distances up to infinity through the use of a relay lens and a test chart. The relay lens's optical properties dictate the required distance between the optic and the test chart, or Collimator Working Distance (WDC), to project the correct simulated distance (SD). This paper provides a method for validating the accuracy of simulated test distances. Successful validation is achieved when the distances at which peak MTF occurs in the real world match the simulated distances at which peak MTF occurs on the collimator fixture, or if both distances are within the depth of field (DoF) of the imaging system in use.



Figure 1. Imatest Collimator Fixture.

Introduction

We present a method for validating the simulated distances from the collimator fixture by comparing MTF results between real world image captures and image captures through the intermediary optic at various nominal test distances. Successful validation is achieved if the distances corresponding to peak MTF of

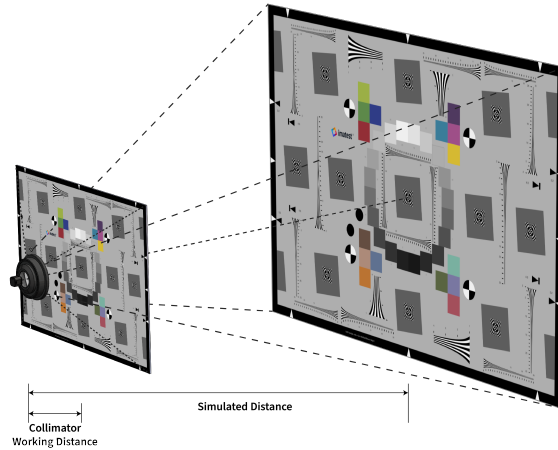

Figure 2. Relay Lens Diagram (Working Distance and Simulated Distance)

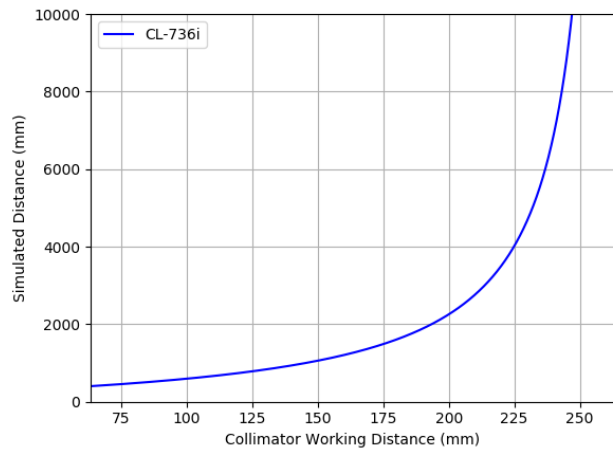

Figure 3. Collimator Working Distance vs Simulated Distance for CL-736i

the real world images match the simulated distances corresponding to peak MTF of the collimator fixture images, or if both distances are within the DoF of the imaging system in use.

Maximum Allowable Working Distance Error

The relay lenses used in this system share a common formula for calculating SD from WDC [1]. This formula is described in Equation 1 below:

$$SD(WDC) = \frac{-EFL \cdot (WDC + H1)}{WDC + H1 - EFL} - H2 \quad (1)$$

Inversely, the formula for calculating SD as a function of WD_C is described in Equation 2 below:

$$WD_C(SD) = \frac{(-1 \cdot SD - H2) \cdot EFL}{-1 \cdot SD - H2 - EFL} - H1 \quad (2)$$

Each relay lens has an effective focal length (EFL) and optical principal points ($H1$ & $H2$) provided by the lens manufacturer. As collimator working distance increases, resulting simulated distance increases exponentially (see Figure 3). Validation is required to verify the accuracy of the relay lens model and the physical WD_C error.

For a given focus distance, the imaging system's DoF can be approximated. Equation 3 and Equation 4 below [7] are used to determine the Hyperfocal Distance (H) and the estimated DoF as a function of focal length (f), F-stop number (N), distance to subject (X_0), and circle of confusion, (C). In this paper, we use a machine vision camera with $f = 28.5\text{mm}$, $N = f/2.8$, and pixel pitch = $1.67\mu\text{m}$. We define the acceptable circle of confusion as 2X the pixel pitch of the machine vision camera ($C = 2 \cdot 1.67\mu\text{m} = 0.00334\text{mm}$). Circle of confusion may be defined differently depending on system requirements. The total DoF (D_{Total}) is described as a function of the near DoF (D_N) and the far DoF (D_F).

$$H \approx \frac{f^2}{N \cdot C} \quad (3)$$

$$D_{Total} \approx D_N - D_F \approx \frac{X_0 \cdot H}{H + (X_0 - f)} - \frac{X_0 \cdot H}{H - (X_0 - f)} \quad (4)$$

The imaging system's near and far DoF dictates the maximum allowable near and far WD_C error that the collimator fixture can have for each focus distance. This value is used to set the pass/fail criteria: if the distances corresponding to peak MTF from the real world measurements and collimator fixture measurements are both within the DoF of the imaging system, the collimator fixture would pass. A diagram of the collimator fixture and real world camera DoF is shown below in Figure 4; Labeled distances are not to scale. Using Equations 1-4, the maximum allowable WD_C error is calculated for each nominal focus distance (see Table 1).

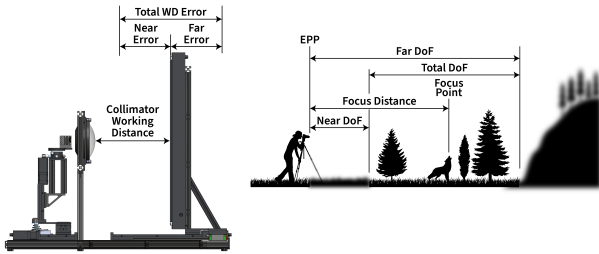

Figure 4. Collimator Target Position Uncertainty and Camera DoF.

Due to the exponential relationship between SD and WD_C , the SD is more sensitive to WD_C error at longer WD_C . Therefore, maintaining the accuracy of longer SD can be difficult. However, the total DoF of an imaging system will generally increase

Table 1: Estimated DoF for Edmund Optics Camera + 35mm lens, f/2.8

Nominal Focus Distance	D_N	D_F	Total DoF	Allowed WD_C Error _N	Allowed WD_C Error _F
	[m]	[m]	[m]	[mm]	[mm]
1.0	0.9889	1.0113	0.0224	0.900	0.906
2.0	1.9556	2.0465	0.0908	1.286	1.297
4.0	3.8251	4.1917	0.3666	1.577	1.592
8.0	7.3275	8.8085	1.4810	1.759	1.776
16.0	13.5148	19.6052	6.0905	1.862	1.881

at longer focus distances up until H . When an imaging system is focused at H , its DoF is approximated to extend to infinity. The maximum allowable error for WD_C is thus expected to increase at longer SD (as seen in Table 1) because the allowed error is dependent on the DoF of the imaging system in use.

Method

We use a machine vision camera with a lockable focus lens (28.5mm EFL, 10.4° Field of View) to verify the accuracy of the collimator fixture at specific nominal test distances. We use the following nominal test distances: 1m, 2m, 4m, 8m, and 16m. For each nominal test distance, the focus of the camera is locked. A set of images are captured at distance intervals above and below the distance at which peak focus occurs, in both the real world and on the collimator fixture. We then use Imatest software to measure and compare the MTFs between real and simulated distance images. The materials used and step by step procedure are listed below.

Materials

- Imatest Modular Test Stand [2] - Chart Holder Module
- Imatest Modular Test Stand - Camera Rail Module (2m Rail)
- Focus Star (43.5" × 43.5" Inkjet target, mounted on foam core) (Figure 14)
- SFRreg Target - 10:1 Contrast (40" × 40" Inkjet, mounted on foam core) (Figure 15)
- Bosch GLM500 Laser Rangefinder
- PLA Rangefinder Holder with 1/4" thread
- ProMaster GH-10 Professional Gimbal Head
- ProMaster Quick Release Plate #6210
- Peak Design Standard Plate for Capture Camera Clip (Model #: PL-S1), ARCA-type
- EO-10012C [3] 1/2" CMOS Color USB Lite Edition Camera
- C Series 5MP 35mm 2/3" Fixed Focal Length Imaging Lens #59-872 [4]
- Mini USB cable
- Laptop with uEye Cockpit installed
- Imatest Automated Collimator Fixture
- CL736i Lens + Lens Plate
- Size "C" Imatest Light Panel
- SFRplus target - 10: Contrast (2" × 2" Chrome on Glass, mounted on Size "C" frame) [5] (Figure 16)
- Calibration kit

Collimator Fixture Alignment Summary

A calibration plate is used as the datum for the collimator fixture alignment process. The front face of this plate is aligned with the X-Y plane on which all relay lenses rest. This plane is a datum for all calculations made in the software model that convert the WD_C to SD .

Before data is collected, the collimator fixture is aligned such that the following specifications are true (refer to Figure 10, 11, 12, and 13 for a coordinate description and diagrams):

- Target is parallel to the calibration plate within $\pm 1.5\text{mm}$ along the X axis over the entire imaging plane
- Target is parallel to the calibration plate within $\pm 1.5\text{mm}$ along the Y axis over the entire imaging plane
- Z position of the center of the target is determined within $\pm 0.125\text{mm}$ of a known datum on the relay lens
- X axis of motion of the camera gantry is parallel to the calibration plate within $\pm 0.125\text{mm}$ per 75mm of translation
- Y axis of motion of the camera gantry is parallel to the calibration plate within $\pm 0.125\text{mm}$ per 75mm of translation
- Camera X-Y position determination is within $\pm 0.5\text{mm}$ of the nominal center of the relay lens
- Camera Z position determination is within $\pm 0.5\text{mm}$ of a known datum on the relay lens

Real World Data Collection Procedure

For each nominal test distance (1m, 2m, 4m, 8m, 16m), the procedure for capturing real world images is followed directly by the procedure for capturing collimator fixture images. For each nominal test distance, the focus of the camera must not be changed between the real world and collimator fixture tests. Real world images are collected first:

1. Place the focus star chart on the chart holder. The base of the chart holder must not move throughout the duration of this test.
2. Mount the camera to the camera rail. The camera should be centered and orthogonal to the target.
3. Position the camera at the nominal real world distance from the target and focus the camera on the focus star (as well as possible) and then lock the camera's focus.
4. After locking the camera's focus, the following steps are taken to determine the actual peak focus distance:
 - (a) The camera is moved towards the target until the image falls out of the DoF (the center of the focus star becomes blurry). This distance is marked on the camera rail indicator as point "a".
 - (b) The camera is moved away from the target until the image falls out of the DoF. This distance is marked on the camera rail indicator as point "b".
 - (c) The camera is moved to the center between points "a" and "b".
5. After determining the peak focus distance, replace the focus star with the SFRreg Target.
6. Record three captures at peak focus distance. Ensure the target is aligned with the center of the image.
7. Replace the camera with the rangefinder.
8. Using the rangefinder, determine the camera entrance pupil position (EPP) to target distance.

9. Additional captures are taken at several increments around the peak focus distance. The additional incremental distances are derived as follows:

- (a) Derive the WD_C for the peak focus distance using Equation 2.
- (b) Derive the additional incremental real world distances using Equation 1 with the following values for WD_C :
 - Derived nominal $WD_C \pm 0.5\text{mm}$
 - Derived nominal $WD_C \pm 1\text{mm}$
 - Derived nominal $WD_C \pm 1.5\text{mm}$
 - Derived nominal $WD_C \pm 2\text{mm}$
 - Derived nominal $WD_C \pm 2.5\text{mm}$
 - Derived nominal $WD_C \pm 3\text{mm}$
 - Additional $\pm 0.5\text{mm}$ increments as needed

10. Capture three images at each additional real world distance derived in step 9.

11. For real world measurements, record the weighted mean MTF frequency at 50% modulus (MTF50) from all four slanted edges of the SFRreg target using the SFRreg Auto module. For distances closer than 5m, MTF compensation [6] is used.

Collimator Data Collection Procedure

For each nominal test distance (1m, 2m, 4m, 8m, 16m), the procedure for capturing real world images is followed directly by the procedure for capturing collimator fixture images. For each nominal test distance, the focus of the camera must not be changed between the real world and collimator fixture tests:

1. Mount the camera to the collimator fixture. The camera's EPP should be centered about the exit pupil of the CL736i lens.
2. Capture three images at the simulated peak focus distance as well as the additional incremental distances determined in Step 4 and Step 9 of the *Real World Data Collection Procedure*.
3. For collimator fixture measurements, record the weighted mean MTF50 for all slanted edges of the Chrome on Glass SFRplus target using the SFRplus Auto module.
4. Verify that focus has not shifted by recording one additional real world capture at the peak focus distance. The results are only considered valid if the MTF50 obtained in the *Real World Data Collection Procedure* has not changed.

Results

In Figures 5-9 below, the blue line (higher values) represents the average real world measurements (weighted mean MTF50 of all four slanted edges using the SFRreg Auto module with MTF compensation) of three images at each incremental distance. The red line (lower values) represents the average collimator fixture measurements (weighted mean MTF50 of all slanted edges using the SFRplus Auto module) of three images at each incremental distance.

For each nominal focus distance (1m, 2m, 4m, 8m, 16m), the Imatest Collimator Fixture passes simulated distance verification. At 1m, 2m, 4m, 8m, the Collimator projects images closer than the intended SD , with a WD_C Error-Near of 0.5mm or less. At 16m, the Collimator projects images farther than the intended SD ,

with a WD_C Error-Far of approximately 0.25mm. This discrepancy can be attributed to an imperfect relay lens model, optical defects, experimental error, and/or an inaccurate calibration. The collimator fixture is calibrated by measuring the offset between the lens plate and the target. An incorrect calibration causes a larger WD_C error, so it is important to check the offset calibration regularly. Testing with this method, the CL-736i relay lens decreases peak MTF50 by an average of 8.4%. Some loss in MTF is expected when adding intermediary optics to the system. Results with this magnitude of MTF loss can still provide meaningful imaging system measurements. Once the MTF loss is understood, it can be compensated for using golden or bronze sample testing. [8]

Table 2: WD_C Validation Result Summary

Nominal Focus Distance	Actual Real World Peak Focus	Actual Collimator Peak Focus	DoF Overlap
[m]	[m]	[m]	[m]
1.0	1.038	1.038	0.022
2.0	2.006	2.015	0.050
4.0	4.028	3.970	0.290
8.0	8.022	7.818	1.020
16.0	15.285	15.645	4.600

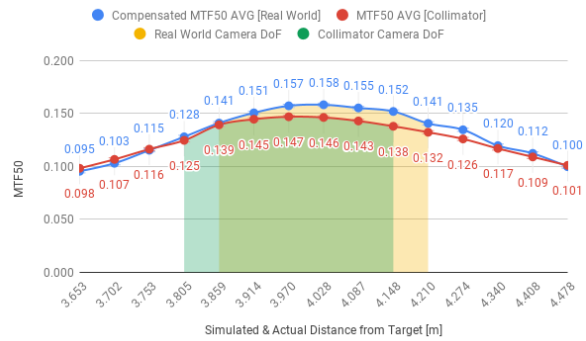

Figure 7. MTF50 VS Simulated/Actual Distance (4m Nominal)

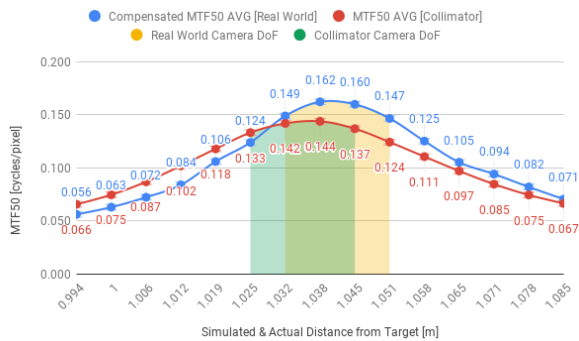

Figure 5. MTF50 VS Simulated/Actual Distance (1m Nominal)

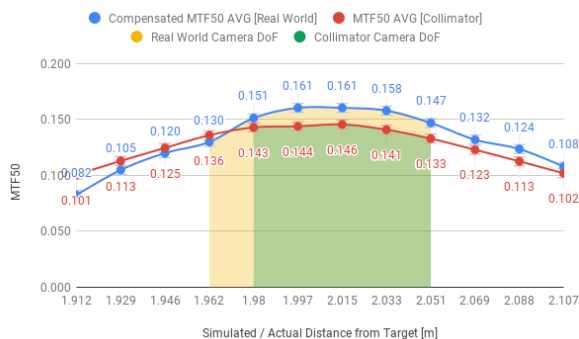

Figure 6. MTF50 VS Simulated/Actual Distance (2m Nominal)

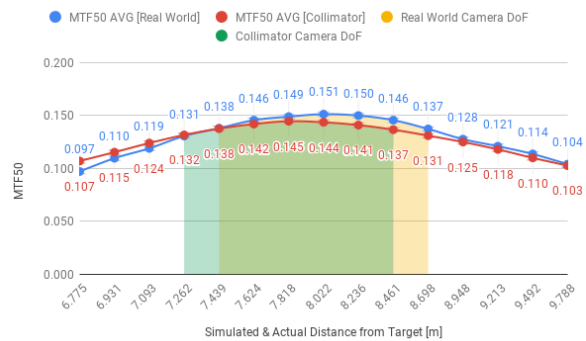

Figure 8. MTF50 VS Simulated/Actual Distance (8m Nominal)

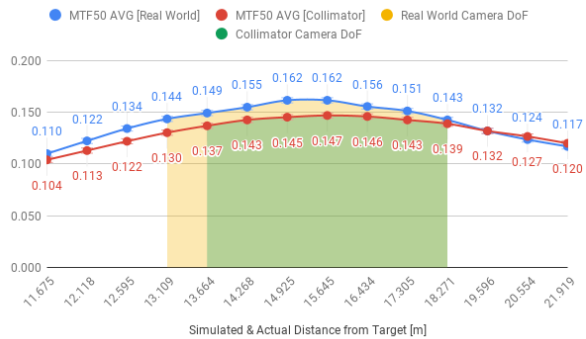

Figure 9. MTF50 VS Simulated/Actual Distance (16m Nominal)

Novelty

- Validation procedure ensures a minimal WD_C error, which provides accurate, repeatable, and known simulated distances.
- WD_C calibration procedure provides the ability to adjust the WD_C offset for any chart thickness or target configuration.
- Camera XY axis calibration procedure provides ability to adjust the XY origin so that the EPP of the camera can be positioned with respect to the nominal center of the relay lens.

References

- [1] Simulated distance equation provided by OneStone - Lens Design & Manufacture.
- [2] "Imatest Modular Test Stand - Imatest Lab Setup - Equipment." <http://store.imatest.com/equipment/imatest-lab-setup/imatest-modular-test-stand.html>. Accessed 29 Jul. 2019.
- [3] "EO-10012C 1/2" CMOS Color USB Lite Edition Camera — Edmund Optics." <https://www.edmundoptics.com/p/eo-10012ccmos-color-usb-lite-edition-camera-/22782/>. Accessed 29 Jul. 2019.
- [4] "C Series 5MP 35mm 2/3" Fixed Focal Length Imaging Lens." <https://www.edmundoptics.com/p/35mm-c-series-fixed-focal-length-lens/16529/>. Accessed 29 Jul. 2019.
- [5] "SFRplus Target on Chrome on Glass - More Transmissive Sharpness" <http://store.imatest.com/test-charts/resolution-charts/trans-charts/sfrplus-chart-chrome-on-glass.html>. Accessed 29 Jul. 2019.
- [6] "Compensating camera MTF measurements for chart and" <http://www.imatest.com/docs/mtf-compensation/>. Accessed 22 Nov. 2019.
- [7] Greenleaf, Allen R., *Photographic Optics*, The MacMillan Company, New York, 1950, pp. 25-27
- [8] "Understanding collimator MTF loss using bronze and golden sample" 9 May. 2019, <http://www.imatest.com/2019/05/understanding-collimator-mtf-loss-using-bronze-and-golden-sample-testing/>. Accessed 29 Jul. 2019.

Author Biography

Alex Schwartz is a graduate of the Engineering Plus program at the University of Colorado Boulder, earning a B.S. in Mechanical Engineering, a certificate in Engineering Management, and a minor in Technology Arts & Media. Alex leads hardware projects, designs new test lab solutions, and creates marketing collateral for Imatest. In his free time, he writes original music and composes acoustic guitar covers. He is a regular open mic performer and enjoys staying active in the Rocky Mountains.

Sarthak Tandon graduated from Rochester Institute of Technology with a B.S. in Mechanical Engineering where he discovered his love for anything mechanical. Sarthak designs and manufactures new hardware and equipment at Imatest to provide fully integrated solutions. In his free time, he tinkers with cars, RC planes, and 3D printers, or off-roads and hikes in the Rocky Mountains.

Jackson Knappen graduated from Rochester Institute of Technology with a B.S. in Imaging Science. Jackson is a member of Imatest's development team and has been recently focused on advancing geometric calibration capabilities. He brings hands-on experience with camera testing development and systems engineering for aircraft remote sensing. Outside work, Jackson's interests include music composition and staying active with his dog.

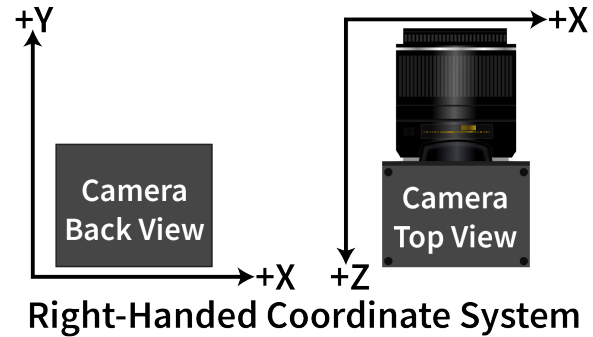

Figure 10. Collimator Fixture Coordinate System

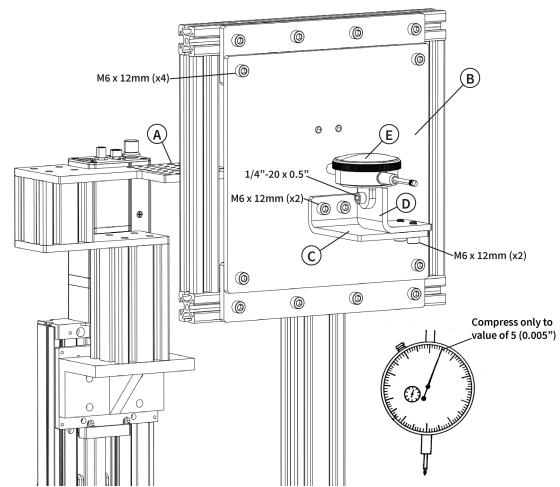

Figure 11. Dial Indicator Configuration for Working Distance Calibration

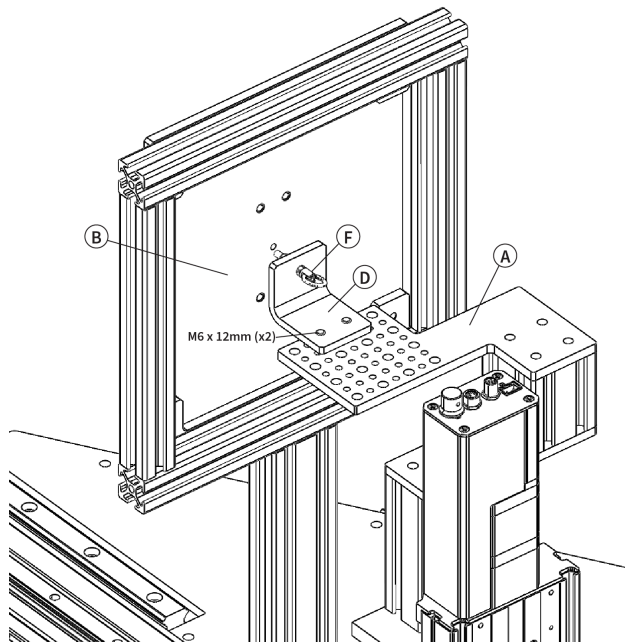

Figure 12. Retractable Spring Plunger Configuration for Camera X & Y axis Calibration

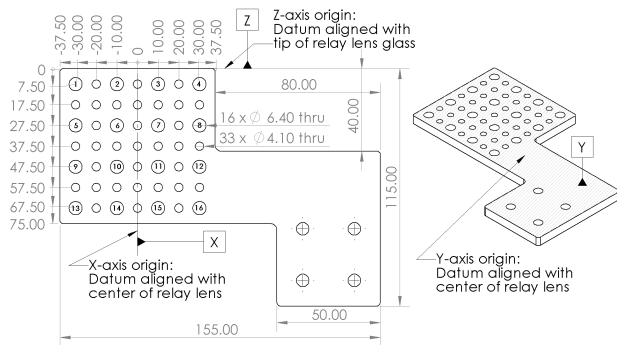

Figure 13. Top Camera Mounting Plate Diagram (Part A)

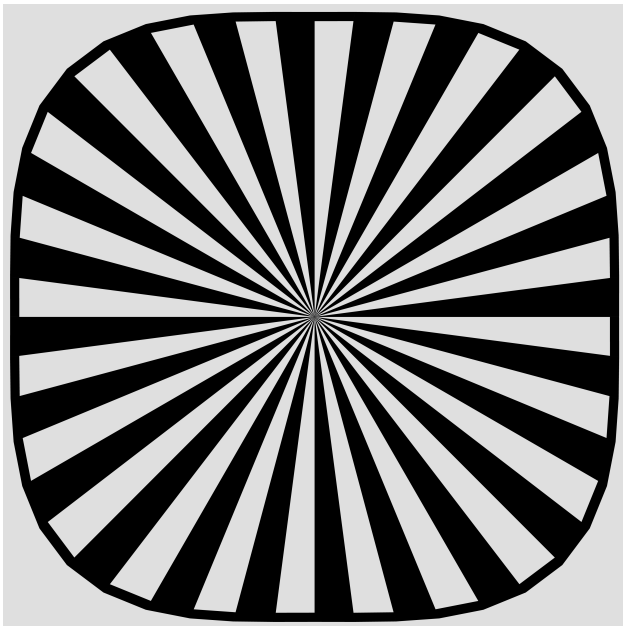

Figure 14. Focus Star Pattern

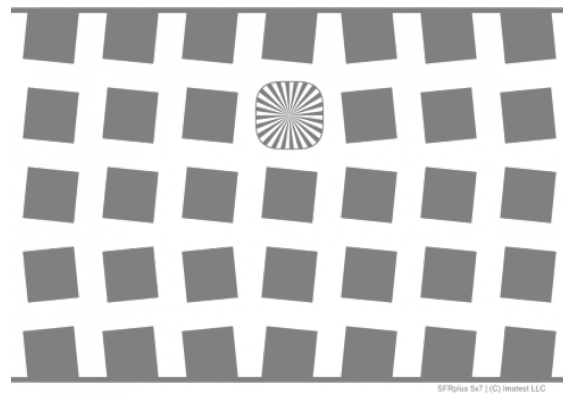

Figure 16. SFRPlus Chrome on Glass Target Pattern

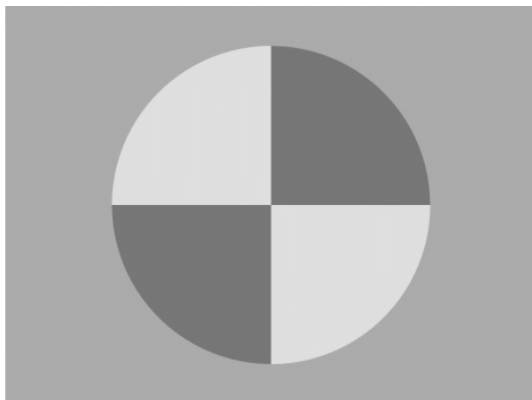

Figure 15. SFRreg Target Pattern

JOIN US AT THE NEXT EI!

IS&T International Symposium on

Electronic Imaging

SCIENCE AND TECHNOLOGY

Imaging across applications . . . Where industry and academia meet!



- **SHORT COURSES • EXHIBITS • DEMONSTRATION SESSION • PLENARY TALKS •**
- **INTERACTIVE PAPER SESSION • SPECIAL EVENTS • TECHNICAL SESSIONS •**

www.electronicimaging.org

