

# Designing a VR Arena: Integrating Virtual Environments and Physical Spaces for Social Sensorial Data-Driven Experiences

Ruth West<sup>1</sup>, Eitan Mendelowitz<sup>2</sup>, Zach Thomas<sup>1</sup>, Christopher Poovey<sup>1</sup>, Luke Hillard<sup>1</sup>, Kathryn Hays<sup>1</sup>, Nathaniel Helgesen<sup>1</sup>; <sup>1</sup>University of North Texas; Denton, Texas/USA, <sup>2</sup>Mount Holyoke College; South Hadley, Massachusetts/USA.

## Abstract

Data-driven use scenarios for virtual and augmented reality are increasingly social, multiplayer and integrated in real world environments, yet these remain limited player experiences in that each player wears a device that enables their immersion and removes them in some sense from the broader physical space and social interactions in which it is occurring. Our work explores one possibility for overcoming these limitations by integrating the virtual environment with the physical space it is occupying through the use of a VR Arena design. We explore the design and development of blended virtual-physical spaces for local multiplayer experiences in which players collaboratively interact with a virtual world created from digital data, and simultaneously perform that data as a soundscape for attendees in a physical space.

## VR/AR/MR in High-Traffic Public Settings

Virtual reality environments immerse us in simulated worlds and experiences. While generated by software, VR also relies upon hardware (e.g. head-mounted displays (HMDs), input/controller devices, workstations) to supplant our surroundings and transport us into the simulated world. Physically covering our eyes and ears, and transforming our hands, appendages, and bodies with controllers, sensors, trackers, and haptics, VR systems purposefully withdraw our human senses from the physical to devote them to the simulated world. With the advent of consumer VR devices, the scenarios for VR's use has radically expanded. The range of shared, social and architectural spaces in which VR systems are used now spans our living rooms, collaboration spaces, art galleries, classrooms, or theme parks, and underwater snorkeling. VR HMDs remove us from the physical world. Regardless of whether the experience is single or multiplayer, HMDs also separate players from contact with others in the physical space that are not sharing the VR experience. Although their bodies are in the same physical space, the experience for those wearing the VR HMD and inside the virtual world is fundamentally different from that of others in the same shared, social, physical or architectural space. This immersion in the VR world isolates the one from the other creating two roles, that of immersed interactor and non-immersed spectator. The increasing installation of VR experiences in high-traffic/high-throughput public settings creates a need for the design of experiences that integrate with their surroundings and are responsive to their social and interpersonal context.

In our work as new media artists, we develop immersive interactive artworks that place virtual reality technologies in public contexts. With this enterprise comes a variety of complications. Some challenges, such as spatial constraints, light or sound control, and power or data connectivity limitations, are unique to the infrastructure at a given venue. While other challenges persist irrespective of the VR installations' setting. A root challenge exists in the implementation of VR technology in public high-throughput environments: there are often more people wanting to engage in the

experience at a given time than available HMDs and/or control devices. A standard approach to this problem is to issue tickets for time-limited experiences with fixed entry times. Representative examples of this approach include VR gaming arcades offering room-scale or free roam experiences [1]–[8], cultural venues such as the Louvre's Mona Lisa Beyond the Glass[9] exhibition or Mass MoCA's Laurie Anderson exhibition[10], and theme park VR attractions [11]–[16]. In response to this root challenge and standard approach to managing access, we ask: *how can we design a more fluid attendee experience?* This question leads us to also consider: *Where does the VR experience start? And where does it end?* To address these questions in the sections below we discuss: What role does embedding of the VR system into a physical/architectural space play in relation to an individual's transition to/from the virtual world? How do we design for passerby or spectator engagement?

We propose that the totality of experience extends beyond the boundary of the virtual/simulated world to the periphery of the VR installation's physical settings where one can first become aware of (see and hear) the VR hardware. We consider the continuum of experience to include the process of transitioning from the physical space within which the VR setup is embedded, into the simulated space via the donning of virtual reality technology. The experience continues both within the virtual world and after exiting the virtual world by removing one's VR hardware thereby transitioning back to the social, shared physical space in which the VR technology is embedded. The bi-directional continuum includes transitions to/from passerby, to spectator, to interactor, and eventually to remote visitors. Below we present an implementation of a prototype free-roam multiplayer VR Arena design with multiple entry/exit points that embodies this continuum of experience. We contend that by minimizing long queues and considering the experience of passersby, spectators, and remote participants in addition to interactors, the VR Arena is able to successfully engage more people than the traditional approach to VR deployments in public settings.

Remote ↔ Passerby ↔ Spectator ↔ Interactor

Figure 1. The continuum of experience in a VR setting with fluid transitions between roles, including passerby, spectator, interactor and remote visitors. See figure 5 for respective interaction zones within the VR Arena.

## Related Work

Arts and entertainment (arcades, theme parks, eSports, etc.) are two of the many settings which are being transformed by the availability of consumer-grade VR devices. In these settings it is important to consider a shared experience between immersed interactors and non-immersed spectators. In the arts, the vast majority of museum-goers cannot interact with the VR artworks because the enjoyment of traditional VR systems is limited by the availability of HMDs. Representative answers to this challenge include the use of projection or display systems presenting the

player's point of view, co-located seating for viewing, and/or the creation of tangible objects or real-world visual elements to provide visitors with a static physical interpretation of the virtual world.

### **VR In Arts and Entertainment Venues**

The VR artwork, *Osmose*[17], by Char Davis, pioneered a combination of these approaches in 1995. In *Osmose* spectators sit in a dimly lit room designed to accommodate the VR installation. The interactor, wearing an HMD and a custom instrumented vest that enables them to navigate and affect the virtual world through their breathing, biometric sensors, and bodily motion, stands backlit behind a translucent screen. The interactor's life-size silhouette is visible to spectators as a physical manifestation in the room via the screen material. Projected on an adjacent wall is the virtual world shown in real-time from the first-person point of view of the interactor. In this way, spectators see what the interactor sees and can make a connection between the interactor's actions as shown on the silhouette display and the virtual world projection. This approach of making the interactor's actions visible to spectators, along with a mirror of the image in the HMD is a common one and often employed with standalone HMD devices[18]–[22] by directing output from the player HMD to one or more LCD displays visible in the space. One drawback to this arrangement is that motion in the video from the HMD caused by the interactor's head movement is incongruent with the spatial orientation of the spectator.

In *Beyond Manzanar*[23] (2000), Tamiko Theil and Zara Houshmand adopt another prominent approach: combining a tangible single user interaction interface placed in a central viewing location combined with room-scale projection of the virtual environment. *Driftnet I*[24] (2007), by Squidsoup, and *Figuratively Speaking*[25] (2012), by Margaret Dolinsky, exemplify the incorporation of head and hand tracked interaction with room-scale projection in CAVE-based[26], [27] environments. In both of these approaches, multiple spectators enter the room and stand near/around the interactor while they “drive” the movement of the player's point of view through the virtual world. In this way, the single-player experience is shared by multiple nearby spectators. Recent works, such as Laurie Andreson and Hsin-Chien Huang's *The Chalkroom*[10] (2019), the Louvre's *Mona Lisa Beyond the Glass*[9] (2019), *CAVE* by Kris Layng et al.[28] (2018) or *Terminus*, by Jess Johnson and Simon Ward[29]–[31] (2019) each utilize multiple HMDs/VR hardware setups, with co-located interactors, seating, and elements of the virtual environment externalized into the physical space as visual or tangible objects. Coming full circle to reflect the approach of Char Davies seminal work *Osmose*, Marshmallow Laser Feast's *We Live in An Ocean of Air*[32] (2019) utilizes free-roaming multiple player HMDs combined with breath sensors, biometrics and player motion to affect the virtual environment. This is combined with large scale projection to externalize the virtual world into the exhibition space. Each of these approaches is effective in establishing a broader physical context for the VR environment.

Embedding the VR technology within a physical space enables some type of spectator viewing. In addition to the arts, VR is emerging as a place-based experience in shopping malls[33], eSports virtual arenas (EVA) [34], roller coaster theme park rides[35] water park slides[36] and underwater snorkeling[37]. Irrespective of artistic, cultural venue, or place-based public experience these implementations all share the same approach to enabling access to visitors: scheduled time slots and time-limited interaction with the virtual world/VR system.

### **Social Acceptability of Extended Reality Devices**

In response to the availability of consumer VR/AR/MR (aka XR, extended reality) technology there is a growing body of research addressing social acceptability of XR devices in public settings. This can inform the design of VR experiences in high-throughput public settings ranging from the arts to entertainment and to casual individual uses of VR/HMD devices in public space. As XR technology develops beyond solitary/personal use of HMDs, a large area of research concentrates on supporting collaborative experiences in remote, asymmetric, or collocated scenarios [38]. These technology research and development efforts focus on the implementation of systems rather than the use and acceptance of the system in social or public contexts. Recent workshops at the ACM CHI Conference on Human Factors in Computing Systems have addressed the social acceptance and public use of XR technology [38],[39], [40]. These highlight the interplay between interactors (performers) and spectators (observers). Work by [41] conceptualizes the use of a computer interface in a public setting as an implicit performance, and conceives of interactors as “performers” and spectators as “observers.” While the act of performing is traditionally reliant on the presence of an audience, these implicit performances require only the presence of an observer, which is often the result of interacting with interfaces in public settings [41]. Thus, VR design must consider the mutual awareness between interactors and spectators. The perceptions of social acceptability for the use of HMDs in shared public space also depends upon the familiarity with the technology and how well the input (interaction) gestures align with what would be deemed as suitable behaviors in a given physical and social context [39], [42].

Along with the need for XR HMDs to support greater social awareness and inclusiveness of others in a shared space comes a growing need for metrics to assess levels of these capabilities. Models that have been applied to date include the Technology Acceptance Model[43], [44], the Unified Theory of Acceptance of Technology[45] and Kelly's WEAR scale[39], [46], [47] yet these do not encompass the full range of potential usage behaviors and new use contexts brought about by the emergent wave of XR technologies[48].

Our work asks, what does it mean to “perform” with an interface in a public setting and how does one design for the spectator experience? Here the work of [41] and of [49] provide the useful nomenclature of manipulations, effects and information asymmetry. The interactor manipulates a primary interface to generate effects, both on content and on the interactor. Revealing or hiding these varied manipulations and effects generates the spectator experience. Manipulations and effects can be hidden, partially revealed, revealed or amplified. This leads to the generation of four categories: secretive (hide both), expressive (reveal or amplify both), magical (reveal effect, hide manipulation), suspenseful (reveal manipulation, hide effects)[41]. Information can also be hidden, partially revealed, revealed or amplified from/to interactors or spectators to enhance the experience[49]. Immersion, a form of isolation, increases presence, yet decreases social acceptability of VR use in public space. To increase the social acceptability of immersion, the need to connect the physical and virtual worlds arises[50]. The intersection of manipulations, effects, and information extends the notion of performance in the context of XR experiences and enables a form of transparency that aligns the work of [51], and [52], in which experiences are designed to accommodate both active spectators (who expect to interact while observing) and passive spectators (who view both virtual and physical environment)

through purposefully revealing or partially revealing manipulations and effects.

## Design Approach

As stated above, a common problem when exhibiting virtual reality work in a public setting is a large number of people interested in using the system relative to the number of available head-mounted displays. The typical solution used by museums is to require timed reservations. Patrons must make a reservation in advance to use the system at a particular date and time. The VR Arena addresses this problem -- too many people and too few HMDs -- differently. It views the VR experience as a fluid continuum that can include casual passersby, engaged spectators, interactors using the HMDs, and even remote visitors. If designed with this approach in mind, not everyone needs to don an HMD to have some engagement with the VR work. Additionally, the VR Area is designed to maximize user throughput allowing more users to interact directly with the VR work without the need for prior reservations.

The VR Arena takes its inspiration from the design characteristics of traditional arenas. Both arenas have a central area in which interactors have a dual role of accomplishing their immediate objectives while also acting as performers for an audience. A gladiator may fight or athlete play hockey, but in doing so they serve a secondary role as performers. Like a traditional arena, the VR Arena provides lines of sight from all directions for spectators coupled with acoustics for all spectators to hear sounds from the interactor's performances.



Figure 2. The free-roaming interaction zones and VR portals enable passersby and spectators alike to engage with the VR world and its content in meaningful ways.

## Continuum of Experience

The VR Arena seeks to create a continuum of experience including passersby, engaged spectators, interactors and remote visitors.

**Passersby** are casual observers, they can hear sounds from the installation, and see spectators, interactors, and technology. Important to the VR Arena concept is that there are no barriers preventing the passerby from becoming an engaged spectator (Figure 3).

**Spectators** are active viewers. In the VR Arena, there is a one-to-one correspondence between the VR coordinate system and the real world. VR cameras are aligned in the virtual world with real-world displays. The common practice of showing an interactor's

point of view on LCD displays or projections can be disorienting as viewpoints are separated from causal actions. Instead, in the VR Arena, the real-world displays provide windows into the virtual world. These windows allow spectators to connect interactor actions with visual and aural effects in the virtual world. Each interactor in the virtual world is represented by a specific color. This color is also applied to the physical VR HMD (Figure 4). This matching of virtual and real-world colors helps connect real-world interactors with their virtual world representation. Being able to simultaneously observe interactors and the virtual world allows spectators to become oriented to the VR world before entering.

**Interactors** have a direct view of the VR world through HMDs. In the VR Arena, interactor's interactions are gesture-based and intelligible to spectators. Button based interactions can't be seen by spectators instead the VR Arena uses easy to "read" physical metaphors. Interactors tap, strike, pickup, and move virtual objects while their interactions are reinforced with spatialized audio feedback.

**Remote Visitors** are able to examine artifacts (visualizations and sonifications) of the interactors' actions over the internet. Interactors' actions are achieved and uploaded to a server and a remote interface provides an alternative way for people to experience the virtual world.

## Maximizing Throughput

The VR Arena is designed to maximize interactor throughput. It is designed in a physically open configuration that easily adapts to the size of the space it is installed within, so that interactions may enter from any direction. Facilitators help interactors don and remove HMDs. Aiding the facilitators are small shelves and hooks holding the HMDs, controllers, and hygienic masks. We utilize "VR booms[53]" to help with cable management to enable a free-standing and reconfigurable floorplan.



Figure 3. VR Arena open design provides opportunities for passersby to observe and make sense of interactors' performance using the VR portals

Important to the VR Arena concept is that the multiplayer VR experience is both collaborative and continuous. It has no start or end. There is no need to reset the experience for new interactors that join. Instead, interactors may join or leave the VR world at any time. This creates a scenario where one interactor may remain in the experience for a very brief period of time, and another may remain a much longer period of time. When a new interactor enters the experience replacing the prior one that remained for a brief time, the experience is seamless for the interactor that has remained throughout the longer period of time. The experience is also seamless for the new interactor that joined.



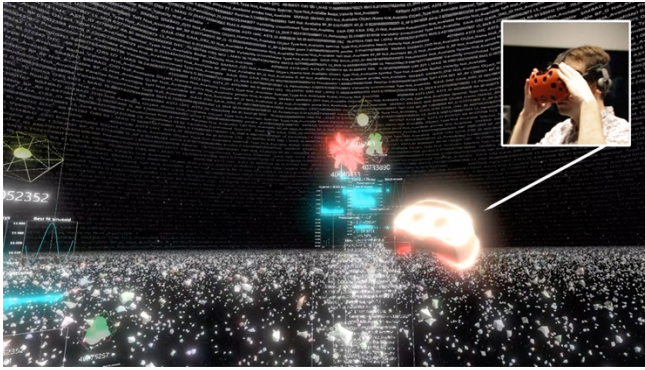

Figure 4. Perspective from within the virtual world (IOAN) showing the red interactor avatar HMD in world and the corresponding red HMD in use by the interactor in the physical VR Arena.

The collaborative and social interaction in virtual reality and in the physical world are consistent with this free flow of interactors into and out of the virtual world, and into and out of the VR Arena. The design of the VR Arena enables both progressive engagement with the virtual reality experience, as well as transparency between virtual and real spaces. The continuum of experience is conceptualized within a series of interaction zones: an inner most interactor zone, a non-immersed spectator zone, a passerby zone, and ultimately a remote (online) interaction mode (Figure 5).

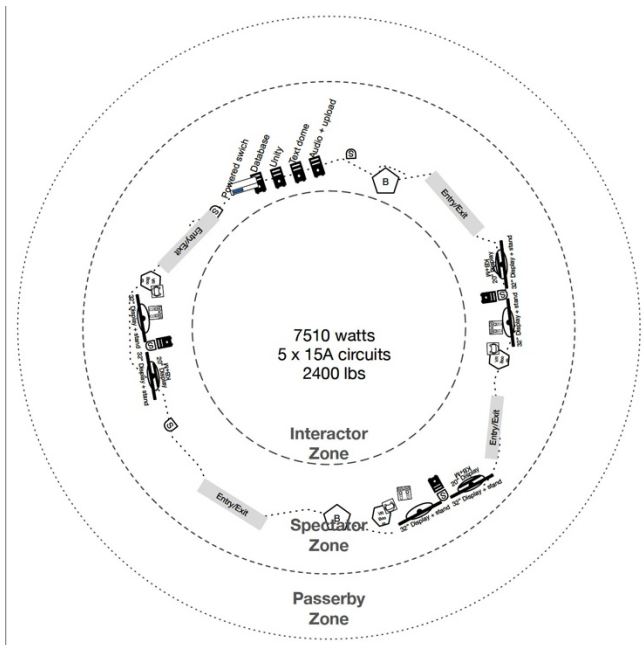

Figure 5. VR Arena prototype. Separated into Interactor Zone (innermost circle), Spectator Zone (housing the VR hardware and computers), and Passerby Zone (outermost circle).

### Prototype implementation: IOAN

IOAN (INSTRUMENT | One Antarctic Night [54]) is an example of a VR Arena installation. It is implemented using Unity and SteamVR. Three Vive HMDs run on three PCs (which also mirror the HMD point of view on small inward-facing displays). A fourth PC running unity acts as a server and drives the three outward facing “windows.” A fifth PC runs a MySQL database containing the astronomical data used by the installation while a sixth PC runs

custom software to display data on another three outward-facing monitors. Finally, a seventh PC acts as an audio server driving a 6.1 speaker ambisonic sound system and 3 stereo headsets. Audio and an archive of interactor actions are uploaded to Amazon S3. All seven PCs are connected via a local area network (Figure 5 and Figure 9).



Figure 6: Visitors to the IOAN VR Arena enter from all sides utilizing multiple entry/exit points.

The four Unity instances communicate over the LAN via Unity’s UNet API. The Unity instances query the database via HTTP requests (which are served via XAMPP). Data is sent to the custom data display software via UDP and to the audio server via OSC. Audio is transported to the speakers over TCP/IP using the Dante network protocol. Each of the four Unity instances must share the same coordinate system. SteamVR is calibrated independently for each of the three HMDs then the portion of the calibration file that establishes the origin of the coordinate system is copied from one machine on the other three so that all four computers use the same coordinate system. The virtual camera must be placed in the virtual world in the same location as the “window” displays occupy the physical world. We locate the displays in Unity coordinate system using Vive controllers and then set the location of virtual cameras based on the observed locations.



Figure 7: Spatially aligned views through “windows” act as portals for non-immersed spectators into the virtual world, while they view and listen to the performance of the virtual world enacted by interactors.



Figure 8: Non-immersed spectators cluster around spatially aligned portals (windows) of the VR Arena.

## Audio Design

Within the VR Arena, IOAN's audio is procedurally generated based on events initiated by interactors in the VR world. Select data fields collected from the server are sent to the audio server software written in Max/MSP. The audio server creates different taxonomies of sound based on the type of interaction in the VR space. For example, tapping an object will create a shimmering bell sound driven both by interactive elements such as how fast the star is tapped, as well as with data parameters such as the power of the star.

A first-order ambisonic mix is generated using the HOA library in Max/MSP[55], [56] and is heard by the spectators and passersby via a 6.1 speaker array on the perimeter of the installation. For each interactor, the global map is translated relative to each interactor's location and the mix is then rotated to the interactors orientation using the IEM ambisonic plug-in suite[57]. The ambisonic mixes are encoded to binaural corresponding interactor's headphones over the LAN via Dante[58]. The ambisonic 6.1 speaker audio generated for the spectators is also mixdown to standard stereo and uploaded to Amazon S3 for the remote viewers. In this way, all audio is specialized appropriately for passersby, spectators, interactors, and remote viewers - the full continuum of experience.

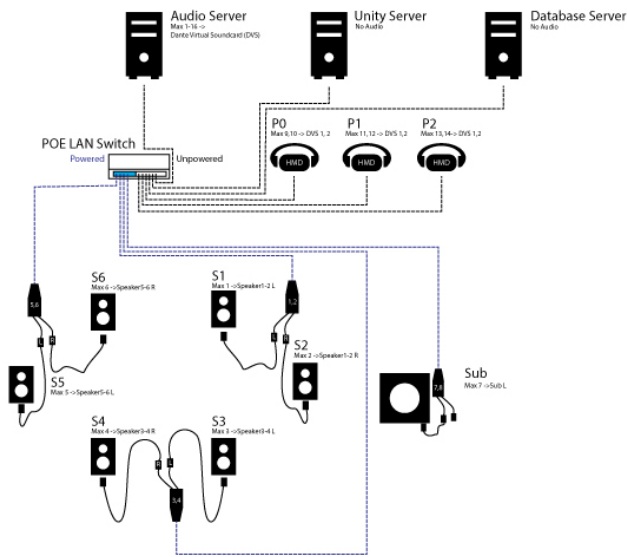

Figure 9. Audio networking diagram for the VR Arena

## Remote

We prototyped remote interaction by creating the Remix-Replay web app. It extends the experience of IOAN from the VR

Arena to online by allowing remote users to interact with a graphic representation of a history of data generated through interaction with the installation as a visual score along with the resulting sound scape. Since this experience is from a non-VR perspective, it encourages users to focus on the compositions created in the installation rather than the exploration of data offered in the installation. In addition to viewing and hearing the soundscape compositions, users may also download mp3 files so they can further remix the data into a new work.

Data is collected throughout any given day of the IOAN installation by the audio server and uploaded to the web application. Data logs contain musical representations such as pitch, velocity and instrument type. Additionally, a stereo mixdown of the originally ambisonic mix is written to a .wav file. Visual score representations are procedurally generated based on information such as pitch, volume, and classification of an action from the installation.

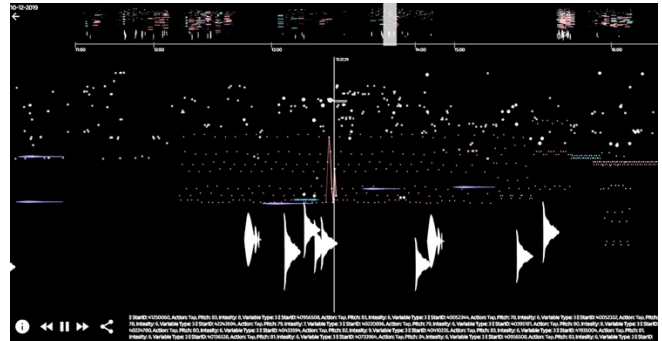

Figure 10. Visual score representation within the web app.

The remix-replay remote user experience extends the VR Arena experience by enabling social media sharing of the soundscape compositions created within the virtual world, and by making those soundscapes available for remixing by anyone regardless of whether they have directly experienced the VR installation or not. It extends the performative aspect of the VR installation beyond the implicit performance of interactor gestures in public space to a broader online audience. It also serves as a direct extension of the experience for immersed interactors who created the soundscapes and anchors their collaboration within the VR Arena within the context of performance.

## Discussion and Future Work

In this work, we present a design approach for a VR Arena along with a prototype implementation (IOAN). Our approach arose in response to a fundamental observation: in public high-throughput environments there are often more people than available HMD devices. A standard solution in use scenarios from the arts, to gaming, entertainment, and theme parks to water slides and even underwater snorkeling is to manage access by issuing tickets for time-limited experiences with fixed entry times. We propose a fluid, bi-directional continuum of experience that reflects, and is informed by recent work in social acceptability of VR HMD use in shared public spaces.

More broadly, we propose the design approach for the VR Arena as an instance of the general challenge of designing XR implementations for public settings with high user traffic/throughput, in which more people are predicted to be present than can simultaneously interact with the XR system and its content. Public XR experiences share design criteria with the VR Arena and recent work in enhancing social acceptability of HMD use in public.

These include the importance of acknowledging context of use, with emphasis on aligning interactors gestures and input modalities with social expectations of observers specific to a given context [42]. Additional contextual factors, such as location, place, and technological infrastructure, along with an understanding of individual's motivation for social interaction, are emphasized in recommendations for interactivity in public spaces by [59]. The work of [60] applies proxemics to public XR exhibits, establishing three interactive zones: an innermost active user zone, a transient zone surrounding the active user zone, and an outermost spectator zone. This is combined with considerations of existing background noise, the number of people in a space, mobility of users, and proximity to visual displays. The work of [61] presents preliminary design guidelines for VR in social spaces that include progressive engagement, transparency between virtual and real spaces, and addressing the context and constraints of the venue, social expectations, and interactive task. We observe that neither VR, nor XR experiences more broadly, begin or end at/with the HMD or controller device, and propose a continuum of experience for immersed interactors and non-immersed spectators reflected in our design approach for a fluid attendee experience.

The IOAN prototype implemented in the VR Arena addresses many of these design concerns while contributing novel design approaches for enhancing throughput and an alternative to queues and issuing tickets for time-limited experiences. Visitors to the VR Arena fluidly transition from the real (physical) space to the virtual by approaching the arena from all sides and entering at one of several entry/exit locations (Figure 5 and 6 above). Virtual world coordinates align with physical world coordinates so that non-immersed spectators, in addition to immersed interactors, experience the virtual world in a way that aligns the physical and the virtual to create a blended experience. Interaction in the virtual world is collaborative and runs continuously, with no need to start or stop the experience in between individual interactors joining or leaving the VR world. Through this collaborative interaction, the immersed interactors perform the virtual world for non-immersed spectators and passersby on two levels: that of implicit interactions inherent to using interfaces in public space, and in the broader sense of performance. This latter performative aspect is enhanced further by the remote online experience (remix-replay).

While promising, the VR Arena prototype is also ultimately constrained by space and attendee flow limitations. The prototype arena has been implemented in a public space as part of an art gallery exhibit in a venue with over 16,000 visitors over the duration of the exhibition[62]. No tickets with specified timeframes were issued for visitors. While throughput to the prototype was increased over standard queues, at times the flow of potential visitors exceeded the capacity of the VR Arena. Non-immersed spectators and passersby clustered by the outward facing windows (Figures 2 and 8). These act as viewing portals, providing spatially aligned views from their position in the physical space into the virtual world. These views enable non-immersed spectators to both view the actions of interactors in the virtual world, and see the immediate effects of interactors manipulations, and see and hear first-hand the performance of the virtual world by interactors, which they can revisit online remotely using the replay-remix app.

Future work in developing the VR Arena includes developing alternative audio design incorporating omni-directional sound sources which enable the sound to be more responsive to alternative configurations of the arena in different physical spaces as well as more effectively spatialized (utilizing a vector based amplitude panning approach) for non-immersed spectators to create “sound-

portals” as a parallel to the visual portals (windows). Our prototype implementation included the use of large scale data to drive the graphics and audio. This required the use of a dedicated audio server, which limited our ability to mirror the installation online for a remote VR experience. Future work will explore the use of cloud computing to enable processing of large scale data sets and development of fully remote VR experiences to mirror the experience in the VR Arena. We will also explore the potential for streamlining the physical components required to implement the VR Arena. The VR Arena is fully self-contained and portable in a set of road cases. In its current implementation the arena utilizes 2400 pounds of electronics and non-electronic hardware, and uses 7510 watts of electricity to create the ephemeral virtual experience for interactors and spectators. That represents a significant amount of non-ephemeral “material” to create an ephemeral experience. We hope to find alternatives to the hardware implementation that are more aligned with the ephemeral nature of virtual experiences making the VR Arena more easily reconfigurable and portable.

## Acknowledgements

This work is sponsored in part by a grant from the US National Endowment for the Arts 15-5400-7043 and by display hardware donations from BENQ America Corporation.

## References

- [1] “Escape Virtual Reality Arcade,” *Escape Virtual Reality Arcade*. [Online]. Available: <https://www.escapevrcade.com>. [Accessed: 11-Feb-2020].
- [2] “Home, VRcade,” *VRcade*. [Online]. Available: <http://www.vrcade.com/>. [Accessed: 11-Feb-2020].
- [3] S. VRArcade, “Shift VR Arcade,” *Shift VR Arcade*. [Online]. Available: <https://shiftvrcade.com/>. [Accessed: 11-Feb-2020].
- [4] “The Rabbit Hole VR Gaming Arcade | Nashville’s #1 VR Experience,” *The Rabbit Hole VR*. [Online]. Available: <https://www.therabbitholevr.com/vr-arcade>. [Accessed: 11-Feb-2020].
- [5] “The VOID | A Virtual Reality Experience,” *The VOID*. [Online]. Available: <https://www.thevoid.com>. [Accessed: 11-Feb-2020].
- [6] D. Arcade, “VR Arcade Installations, Rentals and Sales,” *Dreamland Arcade*. [Online]. Available: <https://thevrcade.com/vr-arcade>. [Accessed: 11-Feb-2020].
- [7] “VR1 Arcade, The First VR Arcade in Idaho!,” *vr1arcade*. [Online]. Available: <https://www.vr1arcade.com>. [Accessed: 11-Feb-2020].
- [8] “Warrior VR arcade,” *Warrior VR Arcade*. [Online]. Available: <https://www.warriorvrcade.com/>. [Accessed: 11-Feb-2020].
- [9] Musee du Louvre, “Mona Lisa: Beyond the Glass.” [Online]. Available: [https://www.viveport.com/apps/18d91af1-9fa5-4ec2-959b-4f8161064796?hl=en\\_US](https://www.viveport.com/apps/18d91af1-9fa5-4ec2-959b-4f8161064796?hl=en_US). [Accessed: 11-Feb-2020].
- [10] “Laurie Anderson | MASS MoCA.” [Online]. Available: <https://massmoca.org/event/laurie-anderson/>. [Accessed: 11-Feb-2020].
- [11] “Battle for Eire Virtual Reality Ride | Busch Gardens Williamsburg.” [Online]. Available: <https://buschgardens.com/williamsburg/rides/virtual-reality-battle-for-eire/>. [Accessed: 11-Feb-2020].



- [12] “Knott’s Berry Farm - VR Showdown in Ghost Town.” [Online]. Available: <https://www.knotts.com/>. [Accessed: 11-Feb-2020].
- [13] “Men In Black International - VR,” *Dave & Buster’s Play Games*, 26-Nov-2019. [Online]. Available: <https://www.daveandbusters.com/play-games/mib-vr/>. [Accessed: 11-Feb-2020].
- [14] “Star Wars™ VR: Secrets of the Empire,” *The VOID*. [Online]. Available: <https://www.thevoid.com/dimensions/star-wars-vr/>. [Accessed: 11-Feb-2020].
- [15] “The Big Apple Coaster.” [Online]. Available: <https://newyorknewyork.mgmresorts.com/en/entertainment/the-big-apple-coaster-and-arcade.html?> [Accessed: 11-Feb-2020].
- [16] “The Great LEGO Race - LEGOLAND Florida Resort.” [Online]. Available: <https://www.legoland.com/florida/map-explore/land-views/lego-technic/rides/great-lego-race/>. [Accessed: 11-Feb-2020].
- [17] “Osmose.” [Online]. Available: <http://www.immersence.com/osmose/>. [Accessed: 11-Feb-2020].
- [18] “Oculus | VR Headsets & Equipment.” [Online]. Available: <https://www.oculus.com/>. [Accessed: 11-Feb-2020].
- [19] “VIVE™ | Discover Virtual Reality Beyond Imagination.” [Online]. Available: <https://www.vive.com/us/>. [Accessed: 11-Feb-2020].
- [20] “PlayStation®VR - Over 500 Games and Experiences. Feel them all,” *PlayStation*. [Online]. Available: <https://www.playstation.com/en-us/explore/playstation-vr/>. [Accessed: 11-Feb-2020].
- [21] “Gear VR with Controller Virtual Reality - SM-R324NZAXAR | Samsung US,” *Samsung Electronics America*. [Online]. Available: <http://www.samsung.com/us/mobile/virtual-reality/gear-vr/gear-vr-with-controller-sm-r324nzaaxar/>. [Accessed: 11-Feb-2020].
- [22] “Mirage Solo & Camera with Daydream | Standalone VR | Lenovo US.” [Online]. Available: <https://www.lenovo.com/us/en/daydreamvr/>. [Accessed: 11-Feb-2020].
- [23] T. Theil and Z. Houshmand, “Beyond Manzanar virtual reality installation.” [Online]. Available: <http://www.mission-base.com/manzanar/>. [Accessed: 11-Feb-2020].
- [24] “Driftnet :: a squidsoup project.” [Online]. Available: <https://www.squidsoup.org/driftnet/>. [Accessed: 11-Feb-2020].
- [25] “Figuratively Speaking,” *Vimeo*. [Online]. Available: <https://vimeo.com/23128551>. [Accessed: 11-Feb-2020].
- [26] C. Cruz-Neira, D. J. Sandin, and T. A. DeFanti, “Surround-Screen Projection-Based Virtual Reality: The Design and Implementation of the CAVE,” p. 8.
- [27] C. Cruz-Neira, D. J. Sandin, T. A. DeFanti, R. V. Kenyon, and J. C. Hart, “The CAVE: audio visual experience automatic virtual environment,” *Commun. ACM*, vol. 35, no. 6, pp. 64–72, Jun. 1992, doi: 10.1145/129888.129892.
- [28] K. Layng, K. Perlin, S. Herscher, C. Brenner, and T. Meduri, “CAVE : Making Collective Virtual Narrative: *Best Paper Award*,” *Leonardo*, vol. 52, no. 4, pp. 349–356, Aug. 2019, doi: 10.1162/leon\_a\_01776.
- [29] “Heide X Experimenta,” *Heide Museum of Modern Art*, 14-Nov-2019. [Online]. Available: <https://www.heide.com.au/events/heide-x-experimenta-virtual-reality-symposium>. [Accessed: 11-Feb-2020].
- [30] “Jess Johnson: Balnaves Contemporary Art Intervention.” [Online]. Available: <https://nga.gov.au/balnaves/johnson-ward.cfm>. [Accessed: 11-Feb-2020].
- [31] “Terminus : Jess Johnson & Simon Ward | troublemag.” [Online]. Available: <http://www.troublemag.com/terminus-jess-johnson-simon-ward/>. [Accessed: 11-Feb-2020].
- [32] “We live in an ocean of air.” [Online]. Available: <https://www.marshmallowlaserfeast.com/experiences/ocean-of-air/>. [Accessed: 11-Feb-2020].
- [33] “Review of Owatch IAAPA 2019 Orlando Show | Owatch™,” *Owatch*, 09-Dec-2019. [Online]. Available: <https://www.stekiamusement.com/2019/review-of-owatch-iaapa-2019-orlando-show-17582/>. [Accessed: 11-Feb-2020].
- [34] “EVA Unveils Free-Roaming VR Esports Stadium at Paris Games Week – VRFocus.” [Online]. Available: <https://www.vrfocus.com/2019/12/eva-unveils-free-roaming-vr-esports-stadium-at-paris-games-week/>. [Accessed: 11-Feb-2020].
- [35] “The Great LEGO Race - LEGOLAND Florida Resort.” [Online]. Available: <https://www.legoland.com/florida/map-explore/land-views/lego-technic/rides/great-lego-race/>. [Accessed: 11-Feb-2020].
- [36] L. Stinson, “VR water slides are here. Are you ready?,” *Curbed*, 16-Jul-2018. [Online]. Available: <https://www.curbed.com/2018/7/16/17574352/vr-waterslides-void-ballard/>. [Accessed: 11-Feb-2020].
- [37] “Virtual Reality-Schnorcheln in der Therme Erding › aktiv.” [Online]. Available: <http://www.aktiv-regionalmagazin.de/virtual-reality-schnorcheln-in-der-therme-erding/>. [Accessed: 11-Feb-2020].
- [38] J. Gugenheimer, C. Mai, M. McGill, J. Williamson, F. Steinicke, and K. Perlin, “Challenges Using Head-Mounted Displays in Shared and Social Spaces,” in *Extended Abstracts of the 2019 CHI Conference on Human Factors in Computing Systems - CHI EA '19*, Glasgow, Scotland Uk, 2019, pp. 1–8, doi: 10.1145/3290607.3299028.
- [39] M. Koelle *et al.*, “(Un)Acceptable!?: Re-thinking the Social Acceptability of Emerging Technologies,” in *Extended Abstracts of the 2018 CHI Conference on Human Factors in Computing Systems - CHI '18*, Montreal QC, Canada, 2018, pp. 1–8, doi: 10.1145/3170427.3170620.
- [40] K. Väänänen-Vainio-Mattila, J. Häkkinä, A. Cassinelli, J. Müller, E. Rukzio, and A. Schmidt, “Experiencing interactivity in public spaces (eips),” in *CHI '13 Extended Abstracts on Human Factors in Computing Systems on - CHI EA '13*, Paris, France, 2013, p. 3275, doi: 10.1145/2468356.2479665.
- [41] S. Reeves, S. Benford, C. O’Malley, and M. Fraser, “Designing the spectator experience,” in *Proceedings of the SIGCHI conference on Human factors in computing systems - CHI '05*, Portland, Oregon, USA, 2005, p. 741, doi: 10.1145/1054972.1055074.
- [42] F. Alallah *et al.*, “Performer vs. observer: whose comfort level should we consider when examining the social acceptability of input modalities for head-worn display?,” in *Proceedings of the 24th ACM Symposium on Virtual Reality Software and Technology - VRST '18*, Tokyo, Japan, 2018, pp. 1–9, doi: 10.1145/3281505.3281541.
- [43] F. D. Davis, “A technology acceptance model for empirically testing new end-user information systems: Theory and results,” PhD Thesis, Massachusetts Institute of Technology, 1985.

- [44] Y. Lee, K. A. Kozar, and K. R. T. Larsen, "The Technology Acceptance Model: Past, Present, and Future," *Commun. Assoc. Inf. Syst.*, vol. 12, 2003, doi: 10.17705/1CAIS.01250.
- [45] V. Venkatesh, M. G. Morris, G. B. Davis, and F. D. Davis, "User Acceptance of Information Technology: Toward a Unified View," *MIS Q.*, vol. 27, no. 3, pp. 425–478, 2003, doi: 10.2307/30036540.
- [46] N. Kelly, "The WEAR Scale: Development of a measure of the social acceptability of a wearable device," p. 233.
- [47] P. Eghbali, K. Väänänen, and T. Jokela, "Social acceptability of virtual reality in public spaces: experiential factors and design recommendations," in *Proceedings of the 18th International Conference on Mobile and Ubiquitous Multimedia - MUM '19*, Pisa, Italy, 2019, pp. 1–11, doi: 10.1145/3365610.3365647.
- [48] Y. K. Dwivedi, N. P. Rana, A. Jeyaraj, M. Clement, and M. D. Williams, "Re-examining the Unified Theory of Acceptance and Use of Technology (UTAUT): Towards a Revised Theoretical Model," *Inf. Syst. Front.*, vol. 21, no. 3, pp. 719–734, Jun. 2019, doi: 10.1007/s10796-017-9774-y.
- [49] G. Cheung and J. Huang, "Starcraft from the stands: understanding the game spectator," in *Proceedings of the 2011 annual conference on Human factors in computing systems - CHI '11*, Vancouver, BC, Canada, 2011, p. 763, doi: 10.1145/1978942.1979053.
- [50] A. Zenner, D. Degraen, and A. Krüger, "Addressing Bystander Exclusion in Shared Spaces During Immersive Virtual Experiences," p. 5.
- [51] "Reeves et al. - 2005 - Designing the spectator experience.pdf" .
- [52] "Zenner et al. - Addressing Bystander Exclusion in Shared Spaces Du.pdf" .
- [53] "VR Boom | Omni by Virtuix." [Online]. Available: <https://www.virtuix.com/product/virtuix-vr-boom/>. [Accessed: 16-Feb-2020].
- [54] "INSTRUMENT | One Antarctic Night | A multi-player VR experience bringing the rhythms of the cosmos to life in an endless remix instrument." [Online]. Available: <http://oneantarcticnight.com/>. [Accessed: 17-Feb-2020].
- [55] "Tool: HoaLibrary v2 | Cycling '74." [Online]. Available: <https://cycling74.com/tools/hoalibrary-v2>. [Accessed: 10-Jan-2018].
- [56] A. Sèdes, P. Guillot, and E. Paris, "The HOA library, review and prospects," in *International Computer Music Conference | Sound and Music Computing*, Athènes, Greece, 2014, pp. 855–860.
- [57] D. Rudrich, "IEM Plug-in Suite." [Online]. Available: <https://plugins.iem.at/>. [Accessed: 17-Feb-2020].
- [58] "Audinate - Dante Audio Networking, AV's Leading Technology," *Audinate - Dante Audio Networking, AV's Leading Technology*. [Online]. Available: <https://www.audinate.com/>. [Accessed: 17-Feb-2020].
- [59] "Väänänen-Vainio-Mattila et al. - 2013 - Experiencing interactivity in public spaces (eips).pdf" .
- [60] A. Jylhä, C. Erkut, and G. Jacucci, "I Can Hear You – Private, Public, and Social Sonic Interactions in Public Spaces," p. 5.
- [61] J. Desnoyers-Stewart, "Transcending Projection: Progressive Engagement with Virtual Reality in Public Spaces," p. 5.
- [62] "ACM SIGGRAPH 2018," *SIGGRAPH 2018*. [Online]. Available: /. [Accessed: 17-Feb-2020].

## Author Biography

*Please submit a brief biographical sketch of no more than 75 words. Include relevant professional and educational information as shown in the example below.*

*Ruth West is an artist and researcher. Ruth is a professor at University of North Texas and director of the xREZ Art + Science Lab (<http://xrezlab.com>). She creates data-driven, social and sensorial extended reality experiences. Her research focus is in art + science integration. She serves on the Board of Leonardo/ISAST.*

*Eitan Mendelowitz is a computer scientist and media artist. Eitan creates data driven interactive art, real-time-media for performance, and public art installations. His research focus is on authoring systems for interactive media environments. Eitan is a Visiting Assistant Professor of Data Science at Mount Holyoke College. He holds a PhD (2009) from UCLA in computer science and an MFA (2002) in design | media arts.*

*Zach Thomas is a composer and media artist whose work is characterized by impulse and restlessness. His current work is focused on the use of appropriated technologies and networked performance environments. He is co-director of the music non-profit ScoreFollower, which curates and produces online content for the promotion of contemporary music. He holds a PhD in composition (2018) from University of North Texas.*

*Christopher Poovey is a composer and media artist who strives to create music and software which produces rich and colorful sound and encourages interactive structures. Christopher's music has been played by members of Ensemble Mise-en, the University of North Texas Nova Ensemble, Indiana University's New Music Ensemble, and Indiana University Brass Choir. He is a PhD candidate at the University of North Texas where he is also a graduate researcher at xREZ Art + Science Lab*

*Luke Hillard is a graduate researcher at xREZ Art + Science lab and a computer science Masters candidate at University of North Texas. His research focuses on data analysis, machine learning and computer engineering for virtual and augmented reality.*

*Kathryn Hays is a research associate at xREZ Art + Science Lab. Her research interests include cognition and perception in immersive environments, human computer interaction, and creativity in extreme environments. She holds a Masters in Applied Cognition and Neuroscience from University of Texas Dallas.*

*Nathaniel Helgesen is an undergraduate researcher at xREZ Art + Science Lab. His research interests include computer science and mathematics, and development of immersive experience for virtual and augmented reality.*



**JOIN US AT THE NEXT EI!**

IS&T International Symposium on

# Electronic Imaging

SCIENCE AND TECHNOLOGY

*Imaging across applications . . . Where industry and academia meet!*

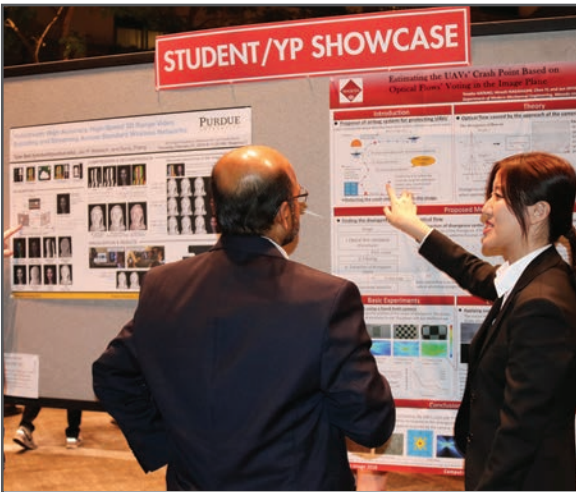

- **SHORT COURSES • EXHIBITS • DEMONSTRATION SESSION • PLENARY TALKS •**
- **INTERACTIVE PAPER SESSION • SPECIAL EVENTS • TECHNICAL SESSIONS •**

[www.electronicimaging.org](http://www.electronicimaging.org)

