

# Mid-air imaging technique for architecture in public space

Ayaka Sano; The University of Electro-Communications; Chofu, Tokyo, Japan

Naoya Koizumi; The University of Electro-Communications; Chofu, Tokyo, Japan

## Abstract

*Mid-air imaging is promising for glasses-free mixed reality systems in which the viewer does not need to wear any special equipment. However, it is difficult to install an optical system in a public space because conventional designs expose the optical components and disrupt the field of view. In this paper, we propose an optical system that can form mid-air images in front of building walls. This is achieved by installing optical components overhead. It displays a vertical mid-air image that is easily visible in front of the viewer. Our contributions are formulating its field of view, measuring the luminance of mid-air images formed with our system by using a luminance meter, psychophysical experiments to measure the resolution of the mid-air images formed with our system, and selection of suitable materials for our system. As a result, we found that highly reflective materials, such as touch display, transparent acrylic board, and white porcelain tile, are not suitable for our system to form visible mid-air images. We prototyped two applications for proof of concept and observed user reactions to evaluate our system.*

## Introduction

A mid-air image is a real image formed by reflecting and refracting the light from a light source and showing it in the air, and superimposing computer graphics (CGs) on real objects is possible. Images can be seen without any head-mounted display (HMD). Moreover, multiple people can see mid-air images at the same time. Therefore, mid-air imaging is promising for glasses-free mixed reality interactions. If an image appears in front of a viewer without any distractions, such as a wall with oddly equipment or wearing HMD, it will attract a great deal of attention and give viewers the feeling of seeing magical phenomenon such as depicted in a science fiction or fantasy movies.

Conventional optical mid-air imaging systems have a drawback in that the optical components are exposed. The optical components and light source are visible together with the image. Therefore, when installing such a system in a public space, the field of view may be disrupted by the optical components. Also, if the viewer notices the mid-air image and the optical components simultaneously, the attractiveness and sense of awe of the mid-air image may decrease. Therefore, it is difficult to apply a mid-air imaging system for architecture in public spaces.

Projection mapping is a method for blending architecture and information in public spaces. It produces a three-dimensional visual effect by using the unevenness of buildings. Even familiar buildings can become impressive with this method. However, since projection mapping alters only the appearance of the architecture, it cannot display images in areas surrounding a building.

In this research, we used mid-air imaging to merge visual information and architecture. We propose an optical system that allows a mid-air image to be displayed in front of viewers without placing the optical components in the field of view. Figure 1 shows a moon, which is a mid-air image, formed with our system, and a figurine as the real object. This is accomplished by placing the light

source and mid-air imaging optical component overhead, shielding the optical component by using louver films, and reflecting by using glossy wall material. We used several wall materials as reflective material and measured the luminance and resolution of mid-air images formed with the proposed system. Based on the results, we selected materials suitable for the proposed system. We then prototyped two applications using the proposed system and exhibited them to observe user reaction.



Figure 1 Mid-air image formed with proposed system. Moon is mid-air image and figurine is real object.

## Related Work

### Mid-air imaging

In this paper, we define an image formed by reflection and refraction of the light from a light source as a mid-air image. Mid-air imaging is an information-presentation method that enables multiple people to view superimposed CGs on real objects. There are several such methods: using dihedral corner reflector array (DCRA) [1], roof mirror array (RMA) [2], aerial imaging plate (AIP) [3], and aerial imaging by retro-reflection (AIRR) [4]. Our optical system uses an AIP because it is easy to use.

Kim et al. proposed MARIO [5] to display a mid-air image in front of viewers by using an AIP. They installed a light source horizontally and placed the AIP 45° above the display. Due to this design, viewers can interact with the mid-air image in front of the imaging optics. However, since the optical components are not shielded, the optical system can be seen by the viewers.

EnchanTable [6] and SkyAnchor [7] form mid-air images using an AIP and reflective surfaces. EnchanTable is an optical system that displays an upright mid-air image on a table using the reflection of the table surface. This system was installed behind the table and hidden using a louver film. This film transmits downward light and diffuses other light. It also enables a real object and a mid-air image to be seen at the same time. However, in such a case, viewers have to adjust their line of sight diagonally downward to see the mid-air image. SkyAnchor displays an anchoring mid-air image onto real moving objects. Users move the real object on a box equipped with

a light source. This makes it possible to superimpose a mid-air image onto a real object. This system also prevents delay without the need to measure the position of the real object and control the light source. With our proposed system, we reflect a mid-air image by using reflecting material as well.

EnchanTable [6], HoVerTable [8], and HoVerTable PONG [9] are mid-air imaging systems using an AIP and louver film. For example, HoVerTable PONG is a tabletop system that displays information by projecting an image on a table surface and forming a mid-air image above the table. The AIP is placed horizontally to the table surface and a double-sided display is used as a light source, which is attached with an XY plotter under the table. The XY plotter is used as actuator to move mid-air images. The light source and louver film move together, making the light source invisible. With our proposed system, we also applied these visibility controlling methods to hide the light source and optical components.

### **Digital signage**

Digital signage is a useful information-display technology because it can show not only images but also movies or interactive displays. It can display appropriate content that varies depending on installation location and time zone, so digital signage is attracting attention as a next-generation advertisement medium. Market size is expanding yearly, and digital signage is also used to improve the coloring of space. However, research on display methods for harmonizing with architectural space has not been extensively investigated.

In public displays, the angle of signage is important, and the influence of angle on viewers differs. In the study by Ichino et al. [10], even from a distance, viewers can view the signage content when the signage angle is nearly vertical. They also argued that multiple people stand behind other people and view the signage together. In the case of a horizontal and tilted angle, the people who view the signage together are most likely acquaintances, but in the case of a vertical signage angle, they are occasionally strangers. These findings suggest that the vertical condition promotes formation of a highly public space with several strangers sharing the space. From these results, a vertical mid-air image can improve not only visibility but also influence the people around it.

### **Projection mapping**

Projection mapping is a method of using computational technology to project images onto buildings to attract viewers. It involves spatial augmented reality (SAR) and changes the actual environment by projecting new graphics on the surface of buildings. For example, it can be used to manipulate texture by projecting a graphic on a white real object. Even if the color of the real object is not white, it can erase the original texture and pattern by using optical correction [11].

The advantage of projection-based AR is that multiple people can view an image simultaneously. Therefore, it is suitable for theme parks that host tens of thousands of people a day [12]. According to Mine et al. [12], the main advantage of projection mapping is that it is possible to create beautiful and dynamic environments that are difficult to achieve with traditional lighting techniques. For example, at the Magic Kingdom Park in Orlando, a show that displays images of park guest taken during that day was held at Cinderella's Castle in 2011. With another system called RoomAlive [13], an image covers the entire room by using multiple projectors and depth sensors. The shape of the furniture and room are measured using the depth sensor, and the calculated image is projected from the projectors. As a result, any room can be transformed into the world of the game, and the user can experience

a higher immersive feeling. Therefore, the fusion of architecture space and computational technology is advanced by projection mapping.

However, projection mapping has several problems. First, it is necessary to prepare multiple high-brightness projectors. Next, since the image is projected on a complicated wall surface, the amount of calculation for processing the image increases. Projection mapping also controls only the texture of the building but cannot display an image detached from buildings. With the proposed system, we aim to present information in a place away from buildings, which is impossible in principle with projection mapping.

### **Architectural materials**

Building materials are important for giving an impression of a building, e.g., glossy materials are widely used to portray luxury. There are many buildings using mirrors and glass to enhance spaciousness. However, people outside a glass-walled room will be able to see inside. To prevent people from peeping inside a room, there are several view-control films that shield the light from a specific direction [14]. By covering objects, such as pillars, with a mirror, it is also possible to hide such objects. In our research, we applied such shielding technology to hide the optical components and harmonize the system with the public space.

## **Proposal**

### **Purpose**

The purpose of our research was to design an optical system of forming mid-air images suitable for public spaces. We designed it to prevent the light source from entering the field of view and display clear mid-air images in front of viewers so as to be in harmony with the environment.

### **Design requirements**

The design requirements of mid-air image optical systems suitable for public spaces are as follows:

1. The mid-air image should be formed in front of the viewer a little distance from the wall.
2. The mid-air image should be displayed in front of the viewer.
3. Optical components should be invisible to the viewer.

Each requirement is described in detail below.

### **Forming mid-air images**

We use a mid-air imaging method to form an image in front of a wall. RMA is low cost, but the formed image is not clear and tilts and stretches a little [2]. AIRR is not expensive, but the brightness is low [4]. Micro-mirror array plates (MMAPs) are expensive, but the brightness is better than with the AIRR, and the image quality is sufficient. There are two types of commercial MMAPs, i.e., AIPs (Asukanet Co., Ltd.) and DCRA (Parity Innovations). In particular AIPs form large high-resolution mid-air images. Therefore, we decided to use the AIP as an optical component to form mid-air images.

### **Direction of viewing mid-air images**

We designed our system to display a mid-air image when the viewer faces the front of a wall. If a system requires the viewer to stop and look downwards to see the mid-air image, the viewer may pass the mid-air image without noticing it. In the worst case, another sign should be installed to make the viewer aware of the mid-air image. However, if we make the mid-air image visible when viewers face frontwards, they will be able to see the image even if they are far away. Therefore, we decided to present mid-air images in front of the viewer.

### Shielding of optical components

We designed the light source and optical components to be over the head so that the viewer can see the mid-air image along with the buildings. If MMAPs are installed in front of a viewer, it is possible to view the mid-air image in front of him/her, but the optical components are also visible. If MMAPs are installed on the ground, the optical path may be interrupted by the foot of the viewer or by him/her stepping on an optical component. Therefore, we decided to install the light source and optical components above the head of the viewer.

The characteristics of MMAPs are not only to reflect light but also to let it pass through. If we place MMAPs above a viewer's head and the viewer looks up from the position where the mid-air image is viewed, the light source will be visible. When the viewer can see the light source, he/she will not focus on the mid-air image. This may also diminish the sense of awe and attractiveness of something popping out of a wall. Therefore, we need to hide the light source.

There are three methods of shielding light: by wavelength, polarization, and orientation. The first method involves using a filter that selectively transmits/absorbs light of a specific wavelength such as a dichroic filter. However, such filters are not easily available due to high cost. Moreover, it is possible to hide the light source but impossible to shield the optical components. The next method involves using a polarizing plate. It is possible to hide the light source by peeling off the polarizer on the surface of the display and placing it in the light path after the mid-air image has passed through the AIP. However, if we apply this method, viewers will see buildings through the polarizing plate, which will disrupt the field of view. The final method involves using a film that transmits only light entering from a specific direction and diffuses or blocks other light. By using such a film, as shown in Figure 2, it is possible to transmit only the light necessary for forming the mid-air image and diffuse or shield the light entering the field of view. As a result, we can hide the optical system and light source, and the viewer can view the mid-air image in front of the wall. Therefore, we used the method that transmits light in a specific direction and diffuses or shields other light.

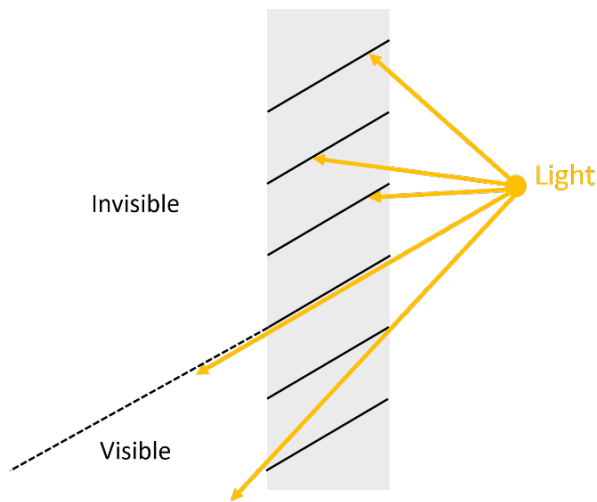

Figure 2 Optical properties of louver film

### Proposed optical system

The proposed system satisfies the purpose and design requirements shown in Figure 3. The system consists of a display (D), reflective material (R), AIP, and louver film (F). The light from D is reflected by the AIP and goes through F, then it is reflected by R and forms a mid-air image.

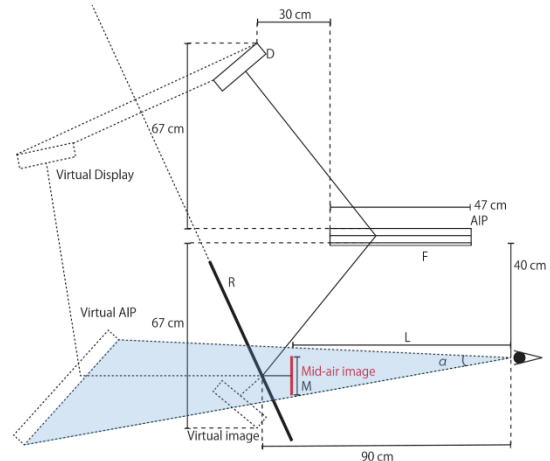

Figure 3 Optical Design and field of view of proposed system

The angular design of D and R is as follows. We tilt D by  $\theta$  and R by  $\varphi$ . Then, the angle is that shown in Figure 4. Thus, the following expression holds.

$$\theta + 2\varphi = 90^\circ \quad (1)$$

$$(0^\circ < \theta < 90^\circ, 0^\circ < \varphi < 45^\circ)$$

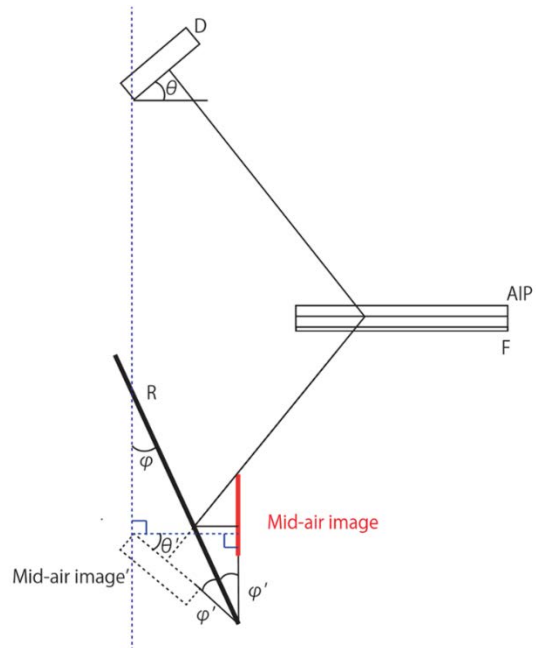

Figure 4 Design angles of display and reflective material

We set  $\theta = 40^\circ$  and  $\varphi = 25^\circ$  to fully use the light from D. If  $\theta$  is  $0^\circ$  or less, the light from D hardly enters the AIP. Similarly, even when  $\theta$  is  $90^\circ$  or more, the light from D hardly enters the AIP. Therefore,  $\theta$  needs to be more than  $0^\circ$  and less than  $90^\circ$ . Also, when  $\varphi$  is  $0^\circ$  or less, viewers cannot see it unless they look up to see the mid-air image. However, when  $\varphi$  is  $45^\circ$  or more, it is necessary for the viewers to look down to see the mid-air image. Therefore,  $\varphi$  needs to be more than  $0^\circ$  and less than  $45^\circ$ .

The F shields the AIP and D placed above the head. We select F, which diffuses rays traveling in the backward direction as viewed from the viewer and transmits light rays toward the near direction. We install it under the AIP to hide the light source and optical components. As shown in Figure 5 and Figure 6, F allows light to pass through to form the mid-air image and prevents unnecessary light from passing through.



Figure 5 (Top) no louver film, (Bottom) with louver film

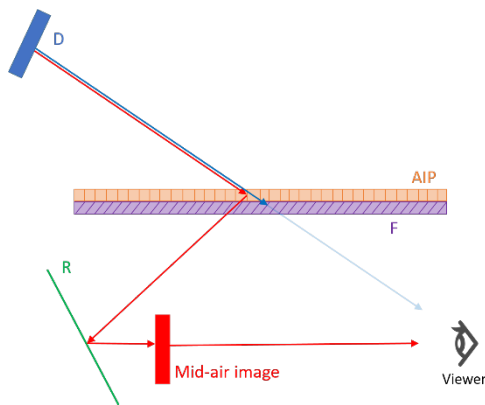

Figure 6 Effect of louver film. Louver film blocks unnecessary light (blue arrow) and allows imaging light (red arrow) to pass for visibility control.

The position of R was designed so that the viewer can observe the real image. Since the distance between the AIP and R is shorter than the distance between D and the AIP, a mid-air image is formed after being reflected by R, as shown in Figure 7 (a). In other words, if we place these components so that  $a > b$ , as shown in Figure 7 (a), the viewer can observe the mid-air image in front of the wall. Since the distance between the AIP and R is longer than that between D and the AIP, as shown in Figure 7 (b), a mid-air image is formed before it is reflected by R. The mid-air image is then reflected in R. In other words, if we place the components so that  $a < b$ , as shown in Figure 7 (b), the viewer cannot observe the mid-air image. To observe a mid-air image from the viewpoint of the viewer, we need to place the components as shown in Figure 7 (a).

The height of the entire system is 260 cm. The display is installed 67 cm higher than the AIP. As a result, vertical mid-air images can be formed 147 cm above the ground, making it possible to see them in the front of R. We denote the height of the mid-air image as M, distance from the viewpoint to the mid-air image as L, and viewing angle as  $\alpha$ . To calculate  $\alpha$ , the following equation is used.

$$\alpha = \tan^{-1} \frac{M}{L} \quad (2)$$

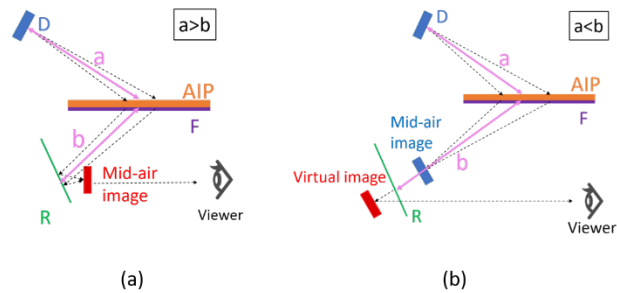

Figure 7 Change in generation position depending on position of reflective material

### Design of field of view

The field of view is summarized in Figure 3. When the viewer is 90 cm from R and he/she can see the mid-air image of 15 cm, the field of view can be calculated using Equation 2. As the viewpoint becomes farther from the mid-air image, M of the mid-air image becomes smaller.

Since a mid-air image basically reflects the light from the light source and re-images it, its field of view is the range between the human eye and AIP. In the case of using a reflective material, the apparent position of the AIP and light source may be regarded as a position symmetrical to R. In other words, the apparent AIP location of the proposed system is the virtual AIP in Figure 3 and the position of D is the virtual display. Therefore, the field of view with this system is the range represented in blue in Figure 3.

### Implementation

Figure 8 shows the details of the proposed system implementation. We use 1022 YH (SUNTEX Industrial Computer, brightness:  $1000 \text{ cd/m}^2$ , 1 pixel = 0.116 mm) as D, the AIP (Asukanet Co., Ltd., 488 mm square) as MMAs, and Winkos vision control film Y - 2555 (LINTEC Corporation) as F. As shown in Figure 9, the range of light from the AIP is between  $40^\circ$  and  $150^\circ$ ,

and the range of undesirable light is 40° to 55°. Therefore, we used Y - 2555, which diffuses light of 25° to 55°.

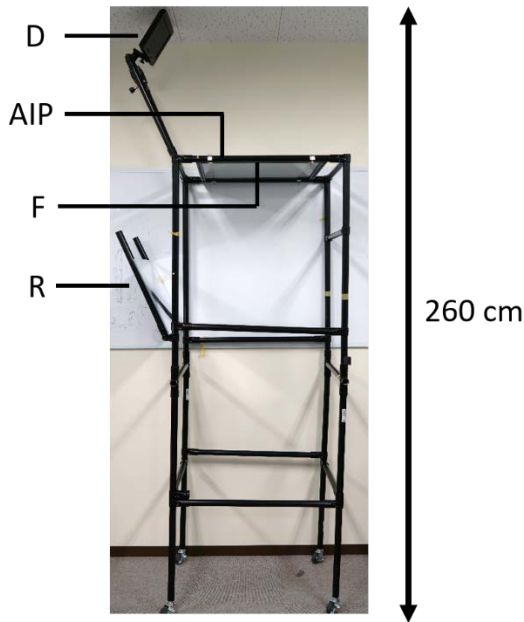

Figure 8 Implemented system

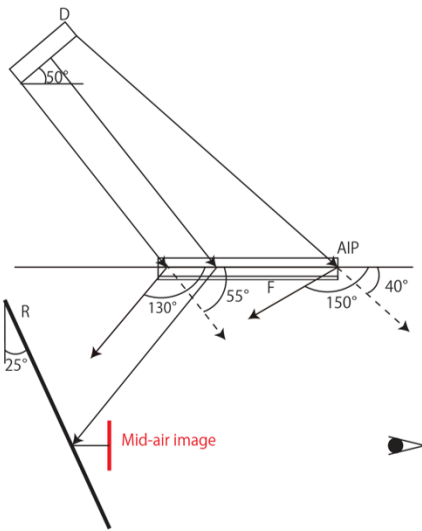

Figure 9 Selection of louver film

## Evaluation

### Evaluation of luminance

#### Purpose

There are many building materials with various gloss properties. Luminance is an important parameter for display. Therefore, we evaluated the luminance of mid-air images formed by reflection of the building materials and selected the reflective

material that can be used to form a more readily visible mid-air image.

#### Procedure

We measured the luminance of mid-air images using a luminance meter (Konica Minolta, Inc., CS-100A). The height of the luminance meter was set to be horizontal to the height of the center of a mid-air image. We used 11 reflective materials: mirror (specular reflection), combiner (reflectance 50%), transparent acrylic plate (reflectance 38%), white acrylic plate (reflectance 5%), black acrylic plate (reflectance 5%), touch display, brown decorative board, white porcelain tile, high-gloss film, mirror film, and steel whiteboard. Two films were attached to the touch display and measured. Figure 10 shows the 11 reflective materials. The measurement conditions are shown in Figure 11. The angles used for measuring luminance were  $\theta = 0^\circ$  to  $20^\circ$ , in  $5^\circ$  increments. Since it is impossible to see a mid-air image if the angles used for measuring luminance are larger than  $30^\circ$ , the measuring range was set to  $20^\circ$ . From the luminance we obtained, we selected reflective materials to use in the experiment.

We also measured how much luminance decreases by installing a louver film. We used three reflective materials; mirror, transparent acrylic plate, and white porcelain tile. In this experiment, the angles used for measuring luminance were  $\theta = 0^\circ$  to  $20^\circ$ , in  $5^\circ$  increments.



Figure 10 Reflective materials used in experiment

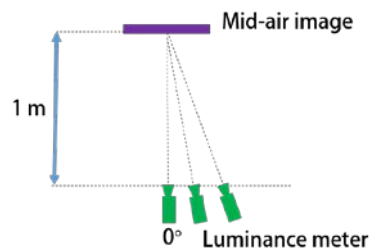

Figure 11 Luminance environment (top view)

## Results

The experimental results are shown in Figure 12. The luminance of the mid-air image formed with the mirror was the highest, and that with the brown decorative board was lowest.

A high luminance mid-air image was formed with glossy materials; mirror, combiner, and mirror film. However, because of the high reflectivity, they also reflected ambient light and showed the optical components and light source. Because these materials are too reflective, we determined that they were not suitable for attracting people's attention to mid-air images. Therefore, we excluded these glossy materials.

The results of excluding the three reflective materials are shown in Figure 12. We chose three reflective materials for the experiments. The first one was the transparent acrylic plate. The plate is a transparent material that can be used for windows. The second one was the touch display. The touch display was selected because it is useful in combination with digital signage. The third one was the porcelain tile. The luminance of the mid-air image formed with the porcelain tile did not seem high, but it is often used as a wall material in public spaces.

Figure 13 shows the results of how much the luminance varies with the presence or absence of a louver film. When there was a louver film, the luminance at 0° was about 80% that without the louver film. However, it was about 60% at 20° using the mirror and transparent acrylic plate.

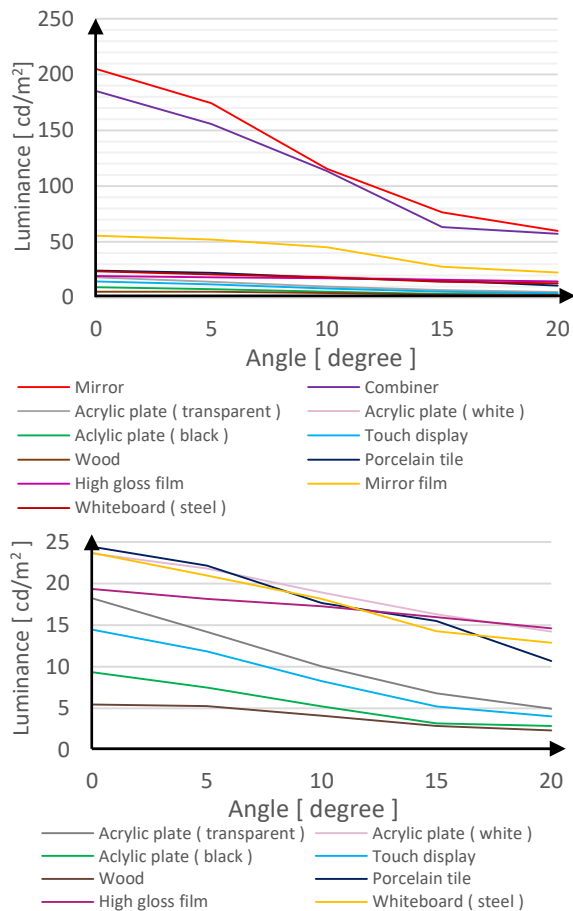

Figure 12 Results of luminance measurement.

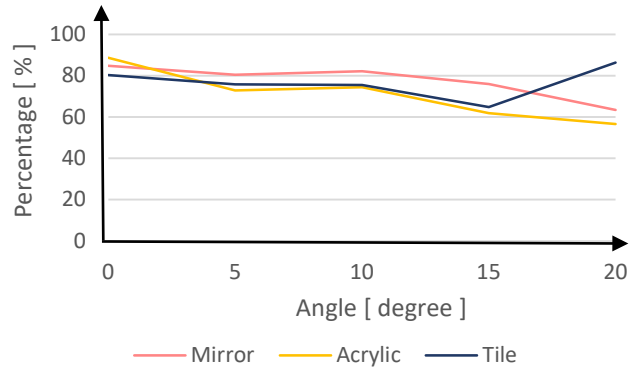

Figure 13 Amount of change in luminance depending on presence or absence of louver film

### Evaluation of resolution

#### Purpose

The resolution of mid-air images is important as well as luminance and differs depending on the reflection characteristics of the material. Therefore, by measuring resolution, we selected the material that can be used to form mid-air images with good visibility.

#### Method

We asked eight people (ages 21 to 23) to participate in this experiment. The participants' eyesight was 0.7 or more based on the Japanese visual acuity test.

We displayed black and white striped mid-air images, one of which is shown in Figure 14. The widths of the black and white stripes were the same. We measured the resolution according to the fineness of the striped pattern that the participants could recognize by using the method of limits. The ascending series increased every 1 pixel from 1 pixel, and the descending series decreased every 1 pixel from 75 pixels. Each participant completed 18 trials. We presented three mid-air images; vertical, horizontal, and diagonal stripes.

We used the three reflective materials we selected for the above experiment.

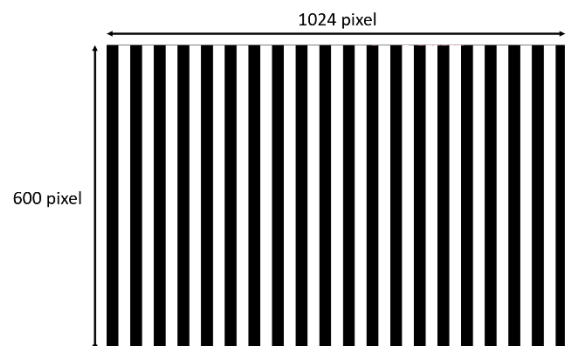

Figure 14 Mid-air image presented in resolution experiment

Figure 15 shows the experimental setup. To fix the eyes of the participants 90 cm from the mid-air image, the position of the jaw was fixed. In each trial, we asked participants to answer whether the image was visible. We randomly changed the reflective material and

the stripe pattern for each series. The ascending and descending series were also randomly conducted.

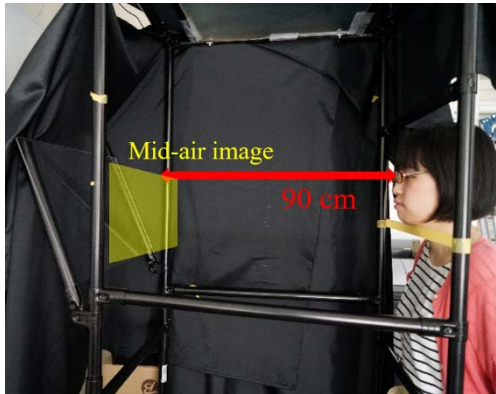

Figure 15 Experimental setup

## Results

The measurement results are shown in Figure 16. The numbers in the graph are the visual angles obtained by converting the average of the lowest thresholds when black stripes and white stripes were clearly visible. The resolution of the mid-air image formed with the porcelain tile was the worst. We also confirmed that light diffused on the surface of porcelain tile surface.

Figure 17 shows the mid-air images formed using each reflective material. The stripe width was 5.5 mm. We confirmed the black and white striped patterns with a mid-air image formed using the transparent acrylic plate and touch display. However, we could not see the boundary of each line of the mid-air image formed using the porcelain tile.

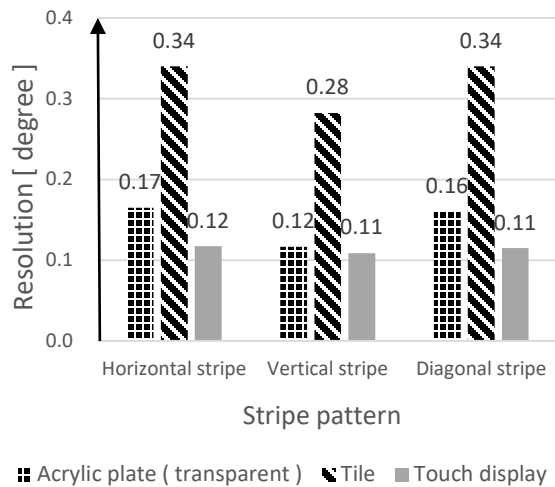

Figure 16 Results of resolution measurement

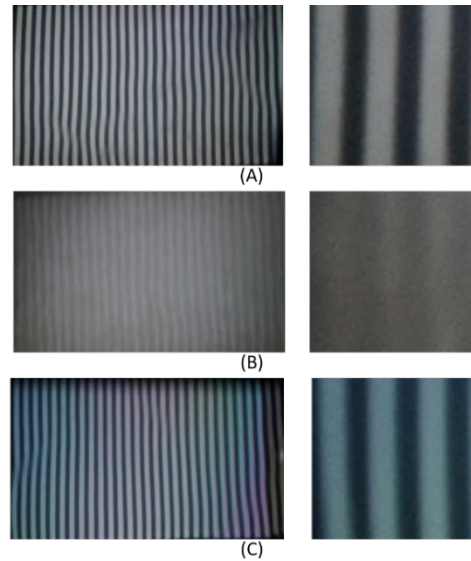

Figure 17 Mid-air images formed when stripe width was 47 pixels. Reflective materials were (A) transparent acrylic plate, (B) porcelain tile, and (C) touch display. Each right image is enlarged view of part of left image.

## Discussion

As shown in Figure 16, using the transparent acrylic plate and touch display formed a mid-air image with a resolution equivalent to  $0.15^\circ$  in terms of viewing angle at which it is possible to recognize the boundaries of large letters, colors, and shapes of objects. Therefore, characters and pictures can be displayed on a signboard with mid-air images. Using the porcelain tile formed a mid-air image with a resolution equivalent to  $0.34^\circ$  in terms of viewing angle at which people can read lettering if the line thickness is 5 mm. Therefore, it is possible to display simple shapes such as numbers and English letters for digital clocks.

When a transparent acrylic plate is used as a reflective material, the mid-air images and real objects at the back of the acrylic plate can be seen simultaneously. If the system is installed in shopping malls, people can see the mid-air advertisement video and sales objects together in front of a wall.

The limitation of our system is brightness. It is impossible to form a mid-air image with high luminance with this system. There are two reasons for this. The first reason is because it is necessary to select a reflective material whose reflectance is not high so as not to show the light source or optical components. The second reason is that the brightness of the display is not sufficient. However, currently available displays have limitation regarding luminance. Therefore, they cannot be installed outdoors at present. If we can develop a high-brightness display, it will be possible to form high brightness mid-air images.

## Application

As a proof of concept of our system, we prototyped two application examples.

### Drawing tool

The first one is a handwritten-message tool made to look like pictures drawn on frosted windows. It is difficult to draw mid-air images in the air without any support because our depth perception is not good [15] and we have to keep our arm up, which may increase fatigue [16]. We used a touch display as an input device and

displayed user's drawings made in air. First, a user drew something directly on the touch display. After 30 seconds, what they drew came out in the air. It was exhibited at our open campus. About 20 people came to use our demonstration. They were university and high school students. Participants scribbled simple shapes, such as circles and hearts, simple illustration of characters, or their initials. To explain the reflective materials, we replaced the touch panel with another material such as acrylic. Most people showed positive reactions when a black acrylic board was installed. According to interviews and their reactions, we assumed that they thought that there was sufficient light for forming mid-air images from the touch display. This observation implies that mid-air images can be displayed in front of walls, which attracts viewers.

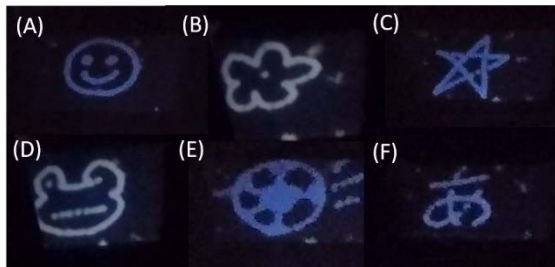

**Figure 18** Example pictures participants drew. (A)-(E) are pictures and (F) is Japanese character. They scribbled simple pictures that can be drawn with single stroke.

### SantaCross

The second application is SantaCross (Santa Claus Cross the front). We developed it for the proof of concept of decorating a wall with mid-air images. In this application, a CG Santa walks repeatedly from side to side and waves his hand at people approaching. A transparent acrylic plate was used as the reflecting material. We set up a display and a tree in the back of the acrylic board and a toy desk and chair in front of acrylic plate. We exhibited it at the Visual Media Expo held from 6 to 8 December 2017 in Yokohama, Japan. Approximately 60 people experienced our demonstration. Most were engineers or researchers, and some were office workers. Some people noticed that Santa Claus waved his hand, and waved back at him. The demonstration space was near a resting space, and the people sitting there noticed the mid-air image and focused on it. Some people came close to our demonstration to take pictures.

From presenting mid-air images together with familiar building materials through these two demonstration exhibits, it was possible to draw attention and instill a sense of awe.



**Figure 19** SantaCross; CG Santa walks repeatedly from side to side and waves his hand at people approaching.

### Future work

With our optical system, a vertical mid-air image can be seen in front of a wall when facing upward. The design of our system is shown in Figure 20. Both the display and reflective material can be installed vertically. In buildings, there are more vertical walls than tilting walls. Therefore, we believe that this design can be used in various places. In everyday life, people look up to see something on a hanging signboard or to see signage. Therefore, we will develop a mid-air imaging system involving hanging signboards.

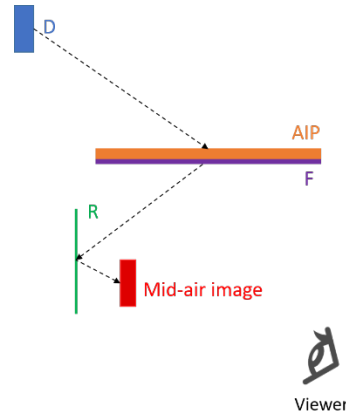

**Figure 20** Proposed optical system that allows vertical mid-air images to be seen when viewers face upward.

### Conclusion

We proposed a mid-air imaging optical system to merge computational technology and architectural design. By installing the optical components over the head, we can display a mid-air image in the front of viewers without the optical system in their sight. To evaluate the proposed system, we measured the luminance and resolution of mid-air images. As a result, a touch display and transparent acrylic plate produced good visibility, equivalent to the viewing angle of  $0.15^\circ$ . We prototyped two applications and exhibited them. As a result, the mid-air images formed with this system may be useful for attractive information displays.

### Acknowledgments

This research was supported by PREST, JST(JPMJPR16D5).

### References

- [1] D. Miyazaki, S. Onoda, Y. Maeda, and T. Mukai, "Blurring Correction for Aerial Image Formed by Dihedral Corner Reflector Array", in Conference on Lasers and Electro-Optics/Pacific Rim, Optical Society of America, 25B1\_3, Busan, South Korea, 2015.
- [2] Y. Maeda, D. Miyazaki, and S. Maekawa: "Aerial Imaging Display Based on a Heterogeneous Imaging System Consisting of Roof Mirror Arrays", IEEE 3rd Global Conference on Consumer Electronics (GCCE), IEEE, pp. 211-215, 2014
- [3] M. Otsubo, "Optical imaging apparatus and optical imaging method using the same", U.S. Patent No. 8,702,252. Washington, DC: U.S. Patent and Trademark Office, 2014.
- [4] Y. Tokuda, A. Hiyama, M. Hirose, and H. Yamamoto, "R2D2 w/ AIRR: Real time & Real space Double-Layered Display with Aerial Imaging by Retro-Reflection", in SIGGRAPH Asia 2015 Emerging Technologies, Article 20, 3 pages, Kobe, Japan, 2015.



- [5] H. Kim, I. Takahashi, H. Yamamoto, S. Maekawa, and T. Naemura, "MARIO: Mid-air Augmented Reality Interaction with Objects", *Entertainment Computing*, vol. 5, issue 4, pp. 233-241, 2014.
- [6] H. Yamamoto, H. Kajita, N. Koizumi, and T. Naemura, "EnchanTable: Displaying a Vertically Standing Mid-air Image on a Table Surface using Reflection", in *International Conference on Interactive Tabletops & Surfaces*, pp. 397-400, Madeira, Portugal, 2015.
- [7] H. Kajita, N. Koizumi and T. Naemura, "SkyAnchor : Optical Design for Anchoring Mid-air Images onto Physical Objects", in *29th Annual Symposium on User Interface Software and Technology*, pp. 415-423, Tokyo, Japan, 2016.
- [8] H. Kim, H. Yamamoto, N. Koizumi, S. Maekawa, and T. Naemura, "HoVerTable: Dual-sided Vertical Mid-air Images on Horizontal Tabletop Display", in *33rd Annual ACM Conference Extended Abstracts on Human Factors in Computing Systems*, pp. 1115-1120, Seoul, Republic of Korea, 2015.
- [9] H. Katsumoto, H. Kajita, N. Koizumi, and T. Naemura, "HoVerTable PONG: Playing Face-toface Game on Horizontal Tabletop with Moving Vertical Mid-air Image", in *13th International Conference on Advances in Computer Entertainment Technology*, Article 50, Osaka, Japan, 2016.
- [10] J. Ichino, K. Isoda, T. Ueda, and R. Satoh, "Effects of the Display Angle on Social Behaviors of the People around the Display: A Field Study at a Museum", in *19th ACM Conference on Computer-Supported Cooperative Work & Social Computing*, pp. 26-37, San Francisco, California, 2016.
- [11] O. Bimber and R. Raskar, *Spatial Augmented Reality: Merging Real and Virtual Worlds*, A. K. Peters Ltd., 2005.
- [12] M. Mine, D. Rose, B. Yang, J. V. Baar, and A. Grundhöfer, "Projection-Based Augmented Reality in Disney Theme Parks", in *Computer*, vol. 45, no. 7, pp. 32-40, 2012.
- [13] B. Jones, R. Sodhi, M. Murdock, R. Mehra, H. Benko, A. D. Wilson, E. Ofek, B. MacIntyre, N. Raghuvanshi, and L. Shapira, "RoomAlive: Magical Experiences Enabled by Scalable, Adaptive Projector-Camera Units", in *27th annual ACM symposium on User interface software and technology*, pp. 637-644, Honolulu, Hawaii, 2014.
- [14] Lintec Corporation, <http://www.wincos-global.com/architectural/vision/>, 2017.
- [15] L. W. Chan, H. S. Kao, M. Y. Chen, M. S. Lee, J. Hsu, and Y. P. Hung, "Touching the void: direct-touch interaction for intangible displays", in *SIGCHI Conference on Human Factors in Computing Systems*, pp. 2625-2634, Atlanta, Georgia, 2010.
- [16] J. Seifert, S. Boring, C. Winkler, F. Schaub, F. Schwab, S. Herrdum, F. Maier, D. Mayer, and E. Rukzio, "Hover Pad: Interacting with Autonomous and Self-Actuated Displays in Space", in *27th annual ACM symposium on User interface software and technology*, pp. 139-147, Honolulu, Hawaii, 2014.

## Author Biography

*Ayaka Sano is an undergraduate student from the University of Electro-Communications.*

*Naoya Koizumi is an assistant professor of the Graduate School of Informatics and Engineering at the University of Electro-Communications. He received his BS (2004) and ME (2006) from the University of Electro-Communications, and PhD (2013) in Media Design from Keio University (KMD). He was a JSPS Postdoctoral Researcher at Keio University (2013) and project researcher at the University of Tokyo (2013-2016).*